ADVANTEST[®]
ADVANTEST CORPORATION

R3267 Series OPT08

Rx Control Option

Operation Manual

MANUAL NUMBER FOE-8370665C00

Applicable models

R3264

R3267

R3273

Safety Summary

To ensure thorough understanding of all functions and to ensure efficient use of this instrument, please read the manual carefully before using. Note that Advantest bears absolutely no responsibility for the result of operations caused due to incorrect or inappropriate use of this instrument.

If the equipment is used in a manner not specified by Advantest, the protection provided by the equipment may be impaired.

- **Warning Labels**

Warning labels are applied to Advantest products in locations where specific dangers exist. Pay careful attention to these labels during handling. Do not remove or tear these labels. If you have any questions regarding warning labels, please ask your nearest Advantest dealer. Our address and phone number are listed at the end of this manual.

Symbols of those warning labels are shown below together with their meaning.

DANGER: Indicates an imminently hazardous situation which will result in death or serious personal injury.

WARNING: Indicates a potentially hazardous situation which will result in death or serious personal injury.

CAUTION: Indicates a potentially hazardous situation which will result in personal injury or a damage to property including the product.

- **Basic Precautions**

Please observe the following precautions to prevent fire, burn, electric shock, and personal injury.

- Use a power cable rated for the voltage in question. Be sure however to use a power cable conforming to safety standards of your nation when using a product overseas.
- When inserting the plug into the electrical outlet, first turn the power switch OFF and then insert the plug as far as it will go.
- When removing the plug from the electrical outlet, first turn the power switch OFF and then pull it out by gripping the plug. Do not pull on the power cable itself. Make sure your hands are dry at this time.
- Before turning on the power, be sure to check that the supply voltage matches the voltage requirements of the instrument.
- Connect the power cable to a power outlet that is connected to a protected ground terminal. Grounding will be defeated if you use an extension cord which does not include a protected ground terminal.
- Be sure to use fuses rated for the voltage in question.
- Do not use this instrument with the case open.
- Do not place anything on the product and do not apply excessive pressure to the product. Also, do not place flower pots or other containers containing liquid such as chemicals near this

Safety Summary

product.

- When the product has ventilation outlets, do not stick or drop metal or easily flammable objects into the ventilation outlets.
- When using the product on a cart, fix it with belts to avoid its drop.
- When connecting the product to peripheral equipment, turn the power off.

- **Caution Symbols Used Within this Manual**

Symbols indicating items requiring caution which are used in this manual are shown below together with their meaning.

DANGER: Indicates an item where there is a danger of serious personal injury (death or serious injury).

WARNING: Indicates an item relating to personal safety or health.

CAUTION: Indicates an item relating to possible damage to the product or instrument or relating to a restriction on operation.

- **Safety Marks on the Product**

The following safety marks can be found on Advantest products.



: ATTENTION - Refer to manual.



: Protective ground (earth) terminal.



: DANGER - High voltage.



: CAUTION - Risk of electric shock.

- **Replacing Parts with Limited Life**

The following parts used in the instrument are main parts with limited life.

Replace the parts listed below before their expected lifespan has expired to maintain the performance and function of the instrument.

Note that the estimated lifespan for the parts listed below may be shortened by factors such as the environment where the instrument is stored or used, and how often the instrument is used.

The parts inside are not user-replaceable. For a part replacement, please contact the Advantest sales office for servicing.

Each product may use parts with limited life.

For more information, refer to the section in this document where the parts with limited life are described.

Main Parts with Limited Life

Part name	Life
Unit power supply	5 years
Fan motor	5 years
Electrolytic capacitor	5 years
LCD display	6 years
LCD backlight	2.5 years
Floppy disk drive	5 years
Memory backup battery	5 years

- **Hard Disk Mounted Products**

The operational warnings are listed below.

- Do not move, shock and vibrate the product while the power is turned on.
Reading or writing data in the hard disk unit is performed with the memory disk turning at a high speed. It is a very delicate process.
- Store and operate the products under the following environmental conditions.
An area with no sudden temperature changes.
An area away from shock or vibrations.
An area free from moisture, dirt, or dust.
An area away from magnets or an instrument which generates a magnetic field.
- Make back-ups of important data.
The data stored in the disk may become damaged if the product is mishandled. The hard disc has a limited life span which depends on the operational conditions. Note that there is no guarantee for any loss of data.

- **Precautions when Disposing of this Instrument**

When disposing of harmful substances, be sure dispose of them properly with abiding by the state-provided law.

Harmful substances: (1) PCB (polycarbon biphenyl)
(2) Mercury
(3) Ni-Cd (nickel cadmium)
(4) Other
Items possessing cyan, organic phosphorous and hexadic chromium and items which may leak cadmium or arsenic (excluding lead in solder).

Example: fluorescent tubes, batteries

Environmental Conditions

This instrument should be only be used in an area which satisfies the following conditions:

- An area free from corrosive gas
- An area away from direct sunlight
- A dust-free area
- An area free from vibrations
- Altitude of up to 2000 m

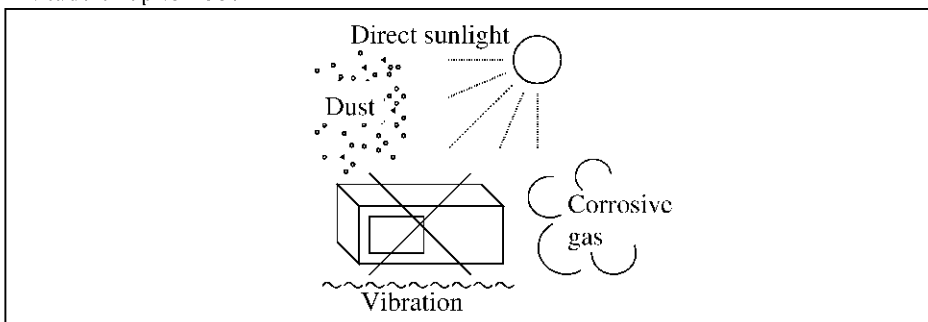

Figure-1 Environmental Conditions

- Operating position

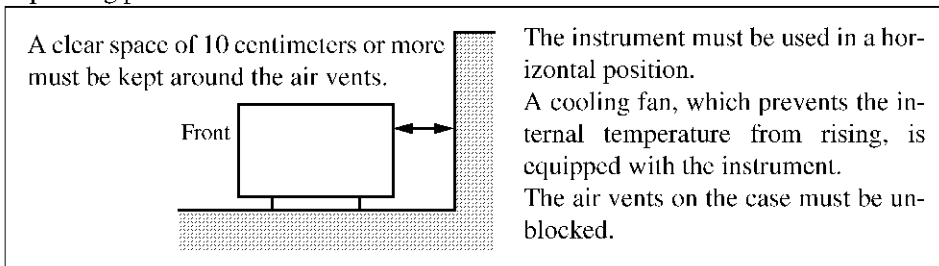

Figure-2 Operating Position

- Storage position

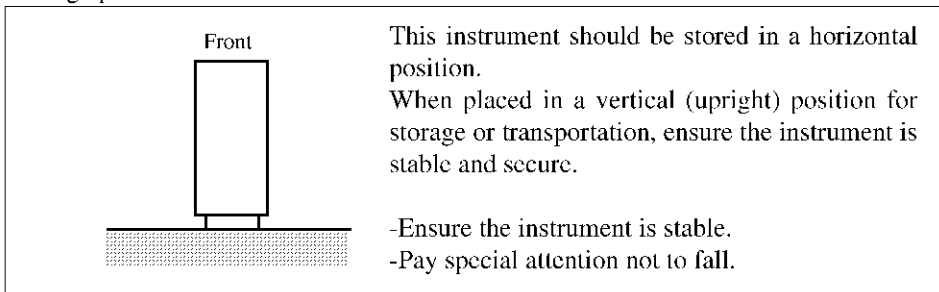

Figure-3 Storage Position

- The classification of the transient over-voltage, which exists typically in the main power supply, and the pollution degree is defined by IEC61010-1 and described below.

Impulse withstand voltage (over-voltage) category II defined by IEC60364-4-443

Pollution Degree 2

Types of Power Cable

Replace any references to the power cable type, according to the following table, with the appropriate power cable type for your country.

Plug configuration	Standards	Rating, color and length	Model number (Option number)
	PSE: Japan Electrical Appliance and Material Safety Law	125 V at 7 A Black 2 m (6 ft)	Straight: A01402 Angled: A01412
	UL: United States of America CSA: Canada	125 V at 7 A Black 2 m (6 ft)	Straight: A01403 (Option 95) Angled: A01413
	CEE: Europe DEMKO: Denmark NEMKO: Norway VDE: Germany KEMA: The Netherlands CEBEC: Belgium OVE: Austria FIMKO: Finland SEMKO: Sweden	250 V at 6 A Gray 2 m (6 ft)	Straight: A01404 (Option 96) Angled: A01414
	SEV: Switzerland	250 V at 6 A Gray 2 m (6 ft)	Straight: A01405 (Option 97) Angled: A01415
	SAA: Australia, New Zealand	250 V at 6 A Gray 2 m (6 ft)	Straight: A01406 (Option 98) Angled: -----
	BS: United Kingdom	250 V at 6 A Black 2 m (6 ft)	Straight: A01407 (Option 99) Angled: A01417
	CCC: China	250 V at 10 A Black 2 m (6 ft)	Straight: A114009 (Option 94) Angled: A114109

TABLE OF CONTENTS

1	OUTLINE OF THE PRODUCT	1-1
1.1	Outline	1-1
2	BEFORE STARTING	2-1
2.1	Confirmation of the accessories	2-1
2.2	How to connect to R3560, R3561 or R3562	2-2
2.2.1	Connecting the R3267 Series to R3560	2-2
2.2.2	Connecting the R3267 Series to R3561 or R3562	2-3
2.3	Serial port setting	2-4
3	HOW TO OPERATE THE R3560	3-1
3.1	Outline	3-1
3.2	Reference	3-2
3.2.1	Menu Index	3-2
3.2.2	Menu Map	3-3
3.2.3	Functional Description	3-4
3.3	Example of the measurement (BER measurement)	3-18
4	HOW TO OPERATE THE R3561	4-1
4.1	Outline	4-1
4.2	Reference	4-2
4.2.1	Menu Index	4-2
4.2.2	Menu Map	4-4
4.2.3	Functional Description	4-6
4.2.4	Preset Values	4-17
5	HOW TO OPERATE THE R3562	5-1
5.1	Outline	5-1
5.2	Reference	5-4
5.2.1	Menu Index	5-4
5.2.2	Menu Map	5-6
5.2.3	Functional Description	5-9
5.3	Measurement Example	5-27
6	HOW TO OPERATE THE R3562 OPT65	6-1
6.1	Outline	6-1
6.2	Reference	6-3
6.2.1	Menu Index	6-3
6.2.2	Menu Map	6-6
6.2.3	Functional Description	6-11

Table of Contents

6.3	Setup Example	6-46
-----	---------------------	------

LIST OF ILLUSTRATIONS

No.	Title	Page
2-1	Connection between R3267 Series and R3560 (Rear panel)	2-2
2-2	Connection between R3267 Series and R3560 (Front panel)	2-2
2-3	Connection between R3267 Series and R3561 or R3562 (Rear panel)	2-3
2-4	Serial port selection screen	2-4
3-1	Initial screen	3-1
3-2	Initial screen (R3560 mode)	3-1
3-3	BER measurement screen	3-5
3-4	Dialog box for BER measurement screen	3-5
3-5	Sens measurement screen	3-7
3-6	Dialog box screen for Sens Parameter setting	3-7
3-7	SETUP setting screen	3-9
3-8	Timing of RF signal output vs the Burst Trigger input signal	3-11
3-9	SLOT setting screen	3-12
3-10	Save operation screen	3-16
3-11	BER measurement screen (in occurrence of Sync error)	3-17
3-12	BER measurement connection	3-18
4-1	Initial screen	4-1
4-2	Initial Screen (R3561 mode)	4-1
4-3	General Dialog Screen	4-6
4-4	Frame A Dialog Box Screen	4-8
4-5	Edit Menu Dialog Box Screen	4-10
4-6	Freq Para. Dialog Screen	4-11
4-7	Level Para. Dialog Screen	4-12
4-8	Other Screen	4-13
4-9	Clock Dialog Box Screen	4-13
4-10	Cal/Self Test Screen	4-15
4-11	Save/Recall Display Screen	4-16
5-1	Initial Screen (For the R3562 Standard Configuration)	5-1
5-2	Initial Screen (with the R3562 OPT 65 Installed)	5-2
5-3	R3562 Control Main Screen (3GPP)	5-3
5-4	BER Parameter Setup Dialog Box	5-9
5-5	Clock/Timing Signal Parameter Setup Dialog Box	5-10
5-6	General Parameter Setup Dialog box (For the Downlink)	5-11
5-7	General Parameter Setup Dialog box (For the Uplink)	5-11
5-8	STD Parameter Setup Dialog box	5-15
5-9	DPCCH Parameter Setup Dialog box (For the Downlink)	5-16
5-10	DTCH/DCCH Parameter Setup Dialog box (For the Downlink)	5-17
5-11	DPCCH Parameter Setup Dialog box (For the Uplink)	5-19
5-12	DTCH/DCCH Parameter Setup Dialog box (For the Downlink)	5-20
5-13	Ext Trigger Parameter Setup Dialog box	5-21
5-14	Frequency Parameter Setup Dialog Box	5-22
5-15	Level Parameter Setup Dialog Box	5-22
5-16	Clock/Timing Signal Parameter Setup Dialog Box	5-23

List of Illustrations

No.	Title	Page
5-17	External I/Q Parameter Setup Dialog Box	5-24
5-18	Save Register List Dialog Box	5-25
5-19	Recall Register List Dialog Box	5-26
5-20	Connecting the DUT	5-27
5-21	STD Parameter Setup Dialog Box	5-28
5-22	General Parameter Setup Dialog Box	5-29
5-23	DTCH/DCCCH Parameter Setup Dialog Box	5-30
5-24	BER Parameter Setup Dialog Box	5-30
5-25	Measurement Result on the Bit Error Rate	5-31
6-1	Initial Screen	6-1
6-2	R3562 Control Main Screen (cdma2000)	6-2
6-3	BER Parameter Setup Dialog Box	6-11
6-4	Clock/Timing Signal Parameter Setup Dialog Box	6-12
6-5	General Parameter Setup Dialog Box <When Reverse Is Set to RC 1 or RC 2>	6-13
6-6	General Parameter Setup Dialog Box <When Reverse Is Set to RC 3 or RC 4>	6-15
6-7	General Parameter Setup Dialog Box <When Forward Is Set to RC 1 or RC 2>	6-18
6-8	General Parameter Setup Dialog Box <When Forward Is Set to RC 3, RC4 or RC5>	6-21
6-9	STD Parameter Setup Dialog box	6-24
6-10	Frame Parameter Setup Dialog Box <When Reverse Is Set to RC 1>.....	6-24
6-11	Frame Parameter Setup Dialog Box <When Reverse Is Set to RC 2>	6-24
6-12	Frame Parameter Setup Dialog Box <When Reverse Is Set to RC 3>	6-25
6-13	Frame Parameter Setup Dialog Box <When Reverse Is Set to RC 4>	6-26
6-14	Frame Parameter Setup Dialog Box <When Forward Is Set to RC 1>	6-27
6-15	Frame Parameter Setup Dialog Box <When Forward Is Set to RC2>	6-27
6-16	Frame Parameter Setup Dialog Box <When Forward Is Set to RC3>	6-29
6-17	Frame Parameter Setup Dialog Box <When Forward Is Set to RC4>	6-29
6-18	Frame Parameter Setup Dialog Box <When Forward Is Set to RC5>	6-30
6-19	Traffic Channel A Parameter Setup Dialog Box	6-31
6-20	PICH Parameter Setup Dialog Box	6-32
6-21	DCCCH Parameter Setup Dialog Box	6-33
6-22	Traffic Channel A Parameter Setup Dialog Box	6-33
6-23	Traffic Channel B Parameter Setup Dialog Box	6-34
6-24	Traffic Channel C Parameter Setup Dialog Box	6-35
6-25	Traffic Channel A Parameter Setup Dialog Box	6-36
6-26	Traffic Channel B Parameter Setup Dialog Box	6-37
6-27	Traffic Channel C Parameter Setup Dialog Box	6-37
6-28	Traffic Channel A Parameter Setup Dialog Box	6-38
6-29	Traffic Channel B Parameter Setup Dialog Box	6-39
6-30	Traffic Channel C Parameter Setup Dialog Box	6-40
6-31	Frequency Parameter Setup Dialog Box	6-41
6-32	Level Parameter Setup Dialog Box	6-41
6-33	Clock/Timing Signal Parameter Setup Dialog Box	6-42
6-34	External I/Q Parameter Setup Dialog Box	6-44
6-35	Save Register List Dialog Box	6-45
6-36	Recall Register List Dialog Box	6-45
6-37	Connecting the DUT	6-46
6-38	STD Parameter Setup Dialog Box	6-47

No.	Title	Page
6-39	Clock/Timing Signal Parameter Setup Dialog Box	6-47
6-40	General Parameter Setup Dialog Box	6-48
6-41	Frame Parameter Setup Dialog Box <Reverse: RC1>	6-49
6-42	Traffic Channel A Parameter Setup Dialog Box	6-50

LIST OF TABLES

No.	Title	Page
2-1	Standard accessories	2-1
3-1	Time defined according to the system mode and the rate	3-11
3-2	Effective setting condition in Burst Trigger functions	3-11
3-3	SACCH settable range	3-13
3-4	Scramble pattern setting range	3-14
3-5	Setting value of the synchronization word	3-15
4-1	Channel Signals	4-9
4-2	Types of CDMA Frame Clock	4-14
4-3	Set Values when Preset (1 of 4)	4-17
4-3	Set Values when Preset (2 of 4)	4-18
4-3	Set Values when Preset (3 of 4)	4-19
4-3	Set Values when Preset (4 of 4)	4-20
6-1	Example 1 showing when the Output Level Supplemental Channel is OFF	6-18
6-2	Example 2 showing when the Output Level Supplemental Channel is OFF	6-18
6-3	Example 1 showing when the Output Level Supplemental Channel is OFF	6-20
6-4	Example 2 showing when the Output Level Supplemental Channel is OFF	6-21
6-5	Example 1 showing when the Output Level Supplemental Channel is OFF	6-23
6-6	Example 2 showing when the Output Level Supplemental Channel is OFF	6-23

1 OUTLINE OF THE PRODUCT

This chapter has summarized the option.

1.1 Outline

When the spectrum analyzer R3267 Series is connected to test a receiver using the R3560, R3561 or R3562, this option enables you to set up the R3560, R3561 or R3562 from the panel on the R3267 Series in order to measure the receiver from the panel on the R3267 Series.

<Features>

- (1) Various settings of R3560, R3561 or R3562 can be performed from the front panel of R3267 Series.
Parameters that can be set:
Frequency, level, modulation type, etc.
- (2) Measurement of R3560, R3561 or R3562 can be performed from the front panel of R3267 Series.
Also, the measurement results can be shown on the display of R3267 Series.

CAUTION:

1. *R3560, R3561 or R3562 GPIB code is not supported in this option. Also, this option does not provide special GPIB commands. Therefore, R3560, R3561 or R3562 cannot be controlled by using R3560, R3561 or R3562 GPIB command from GPIB port of R3267 Series, and also the function of this option cannot be controlled from GPIB.
When you control R3267 Series and R3560, R3561 or R3562 from GPIB by using external personal computer, connect the external computer to both GPIB ports and control them individually.*
 2. *Some functions may not be supported depending on the version of the R3560 main unit.
Before using, contact the nearest ADVANTEST Field Office or representative.*
-

2 BEFORE STARTING

This chapter provides a description of the confirmation of accessories and the connection to R3560, R3561 or R3562.

2.1 Confirmation of the accessories

Check the quantity and rating of standard accessories to assure their conformance with Table 2-1.

Table 2-1 Standard accessories

Items	Specification (Type)	Quantity	Remarks
R3560 interface cable	A01274	1	
R3267 Series OPT08 Operation Manual	ER3267/73OPT08	1	English

Note: Please inform ADVANTEST the type when you order additional accessories.

2.2 How to connect to R3560, R3561 or R3562

2.2 How to connect to R3560, R3561 or R3562

2.2.1 Connecting the R3267 Series to R3560

- (1) Connections on the rear panel

Connect the cable (see note *1) from the serial I/O connector on the R3267 Series to the serial I/O connector on the R3560 as shown in Figure 2-1.

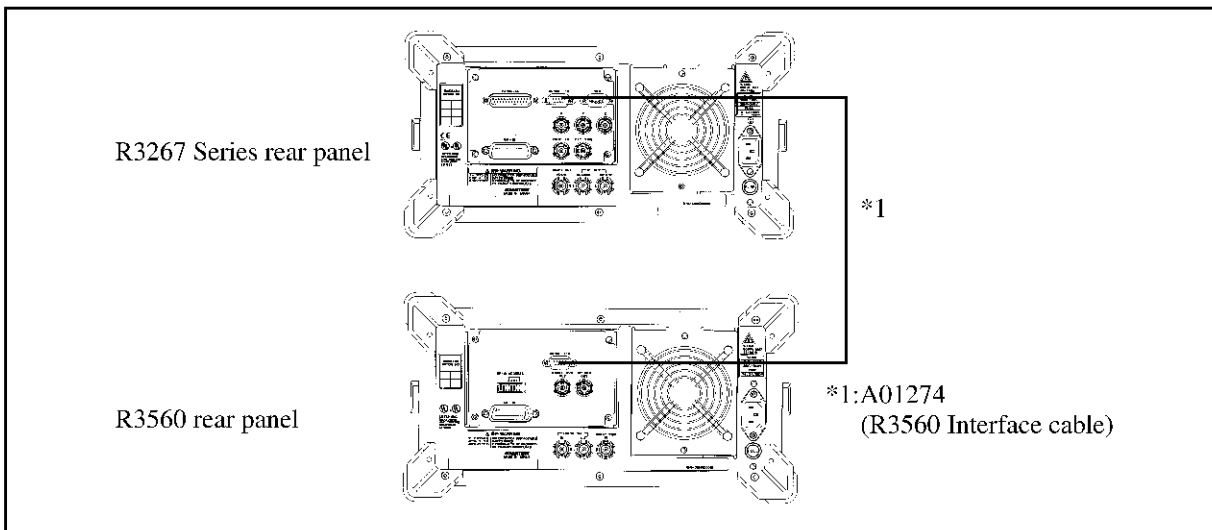

Figure 2-1 Connection between R3267 Series and R3560 (Rear panel)

- (2) Connections on the front panel

Connect the cable (see note *2) from the INPUT 50W on the R3267 Series to the TO ANALYZER 50W on the R3560 as shown in Figure 2-2.

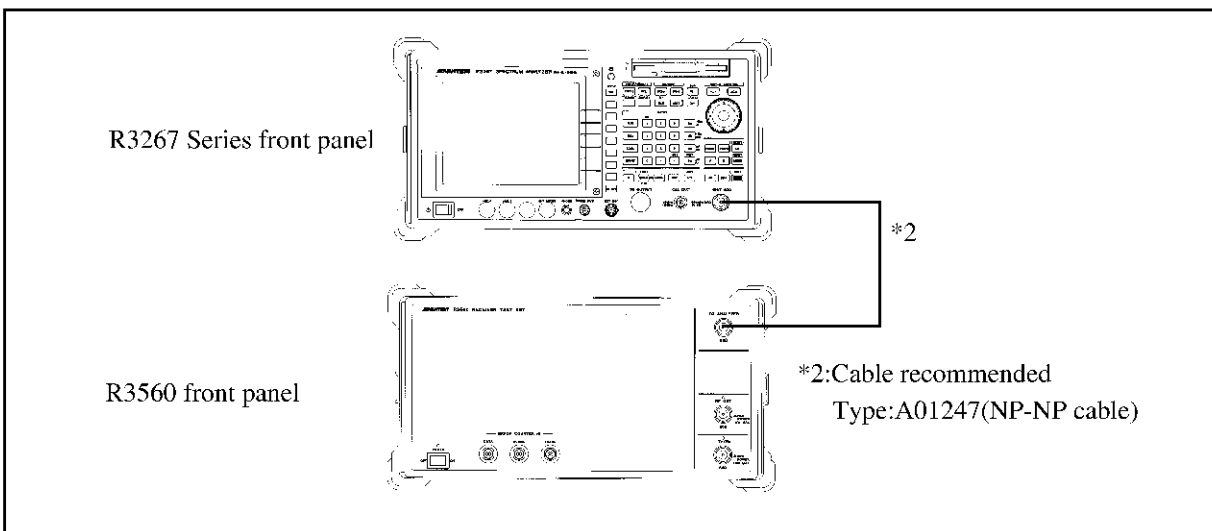

Figure 2-2 Connection between R3267 Series and R3560 (Front panel)

2.2.2 Connecting the R3267 Series to R3561 or R3562

Connections on the rear panels.

Connect the cable (see note *1) from the serial I/O connector on the R3267 Series to the serial I/O connector on the R3561 or R3562 as shown in Figure 2-3 which shows the R3267 Series and R3561 rear panels.

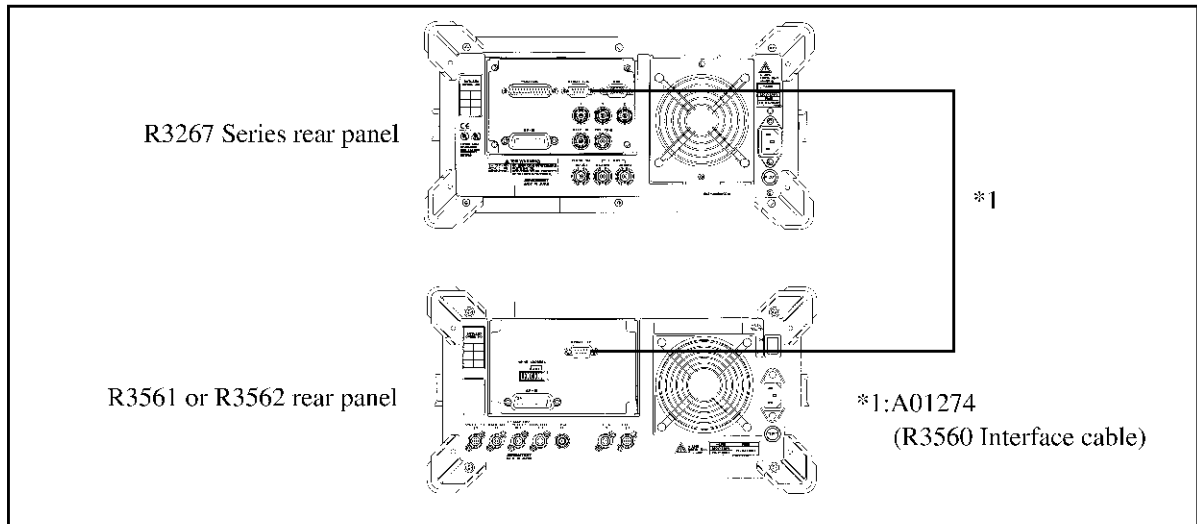

Figure 2-3 Connection between R3267 Series and R3561 or R3562 (Rear panel)

2.3 Serial port setting

2.3 Serial port setting

Pressing **CONFIG** and **RS232** displays the serial port setting menu.
 Before using OPT08, check that Rx Control is selected. If a mode other than Rx Control is selected, change the mode to Rx Control.

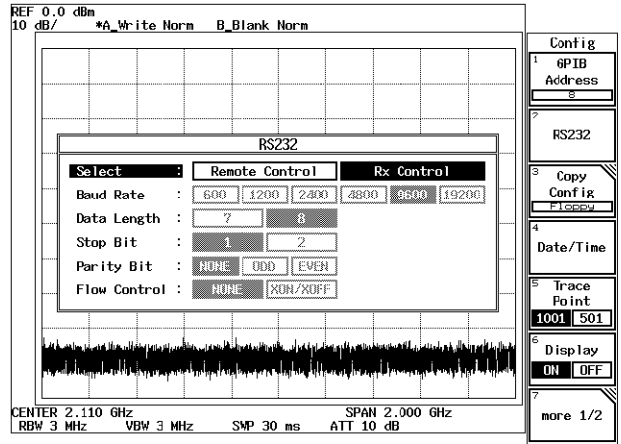

Figure 2-4 Serial port selection screen

3 HOW TO OPERATE THE R3560

This chapter describes all key functions of the R3560.

3.1 Outline

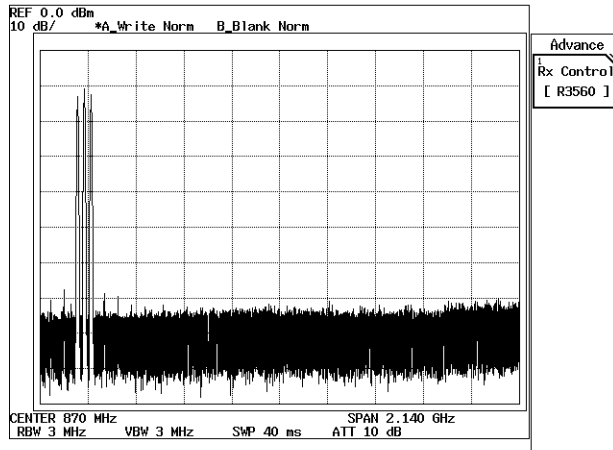

Figure 3-1 Initial screen

The operation menu of R3560 is placed under the **ADVANCE**.

Press **ADVANCE** and **Rx Control [R3560]**, R3267 Series becomes R3560 control mode and displays Initial screen shown in Figure 3-2 to set and measure R3560.

In this mode, operation with only soft-key or dialog box becomes effective except **FREQ** and **LEVEL**. The operation with **SPAN** and so on which can be used in ordinary operation mode cannot be performed. In order to return to the ordinary operation mode, press **POWER**, **UTIL**, **TRANSIENT** or **Quit**.

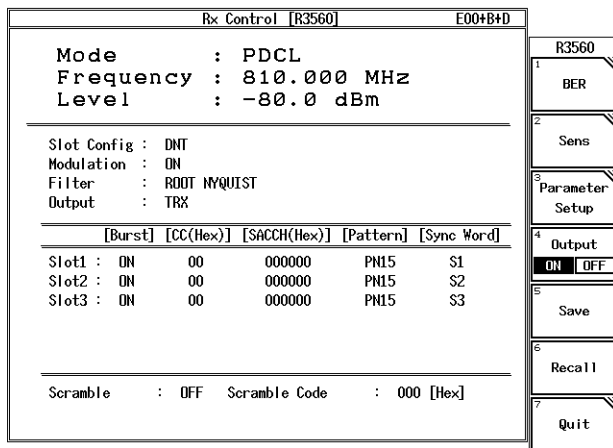

Figure 3-2 Initial screen (R3560 mode)

3.2 Reference

3.2 Reference

This section describes the functions of all panel and soft keys.

- Menu Index: Use this index as a key index to Chapter 3.
- Menu Map: Shows a list of hierarchical menus on a panel key basis.
- Functional Description: Explains the functions of the panel and soft keys.

The panel keys are arranged in alphabetical order.

3.2.1 Menu Index

This menu index is used to easily find the keys described in Chapter 3.

<u>Operation Key</u>	<u>Pages</u>	<u>Operation Key</u>	<u>Pages</u>
Average Times	3-3, 3-6, 3-8	Save Register List	3-3
BER	3-3, 3-5	Scramble	3-3, 3-13
CS	3-14	Scramble Code	3-3, 3-14
Bit Length	3-3, 3-6, 3-8	Recall	3-3, 3-17
Clock Polarity	3-3, 3-6, 3-8	Recall Register List.....	3-3
Color Code	3-3, 3-13	Sens	3-3, 3-7
Burst	3-3, 3-13	Slot	3-3
Burst Trigger	3-3, 3-10	Slot Config	3-3, 3-10
Burst Trigger ON/OFF.....	3-3, 3-6, 3-8	Slot Setup	3-3, 3-12
Data Polarity	3-3, 3-6, 3-8	Start	3-3, 3-8
FREQ	3-4	Step	3-3, 3-8
Filter	3-3, 3-10	Stop	3-3, 3-8
Frame	3-3, 3-6, 3-8	Rx Control [R3560]	3-3
Interval	3-3, 3-6, 3-8	Sync ON/OFF	3-3, 3-6, 3-9
LEVEL	3-4	Sync Word	3-3, 3-15
Level Unit	3-3, 3-10	Target BER	3-3, 3-8
Mode	3-3, 3-9	User Scramble	3-3, 3-14
Modulation	3-3, 3-10	User Scramble Code	3-3, 3-14
Output.....	3-3, 3-10	Trig Polarity	3-3, 3-10
Output ON/OFF	3-3, 3-6, 3-8, 3-15	Trigger Delay	3-3, 3-11
PS	3-14		
Parameter Setup	3-3, 3-5, 3-7, 3-9		
Pattern	3-3		
Quit.....	3-3, 3-6, 3-9		
SACCH	3-3, 3-13		
Rate	3-3, 3-12		
Save.....	3-3, 3-16		

3.2.2 Menu Map

All R3560 soft menus, which are under the **ADVANCE** key, are shown below.

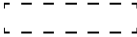
NOTE:  Represents a panel key.
 Represents a dialog box.
 Unless otherwise noted, the soft menus are shown.

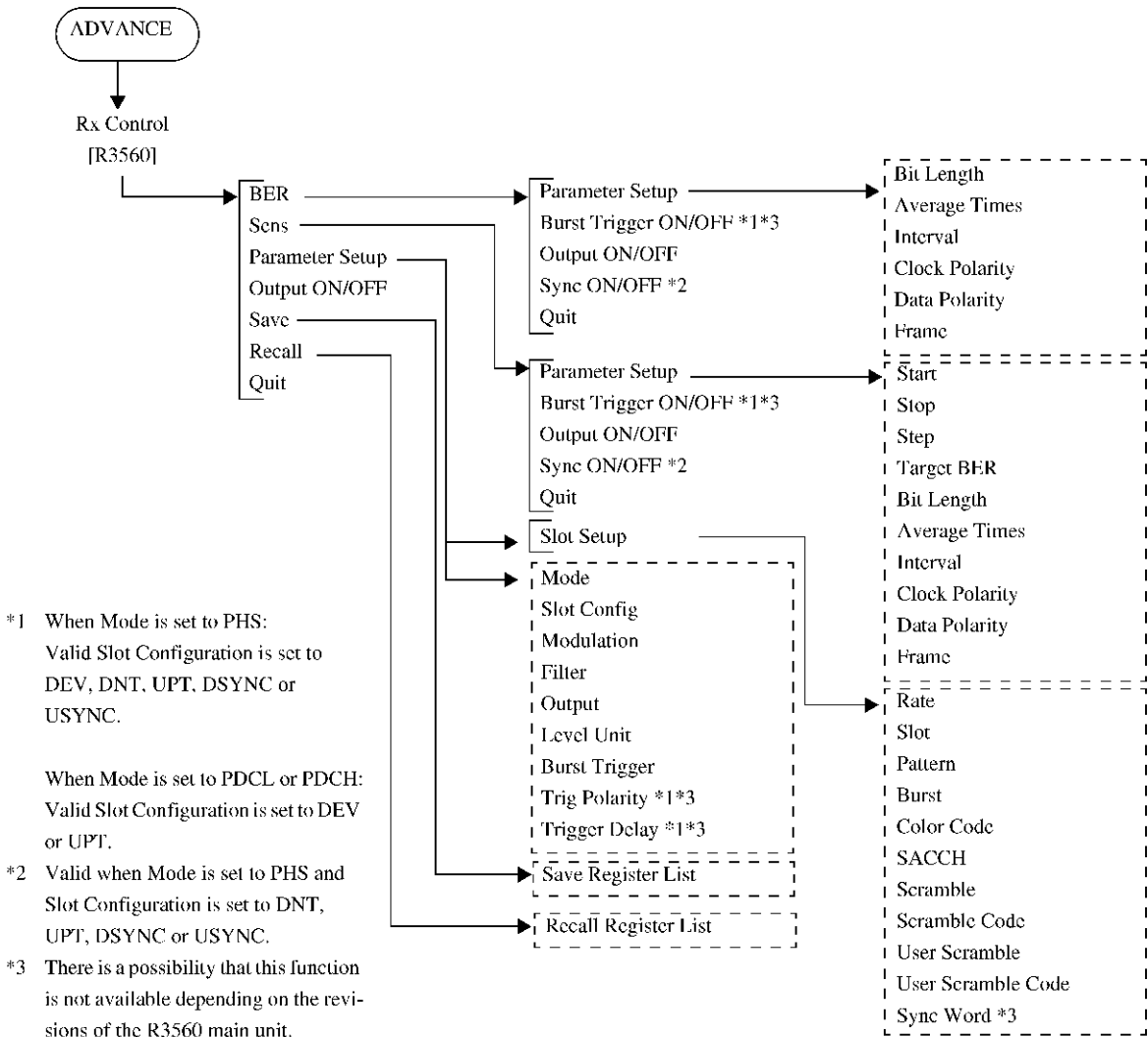

3.2 Reference

3.2.3 Functional Description

- (1) Output frequency setting

FREQ

Sets output frequency.

The frequencies which can be set are different depending on the system mode.

PDCL: PDC 800 MHz band

PDCH: PDC 1.5 GHz band

DNT: Downlink traffic channel

UPT: Uplink traffic channel

PHS: 1.9GHz band

- (2) Output level setting

LEVEL

Sets output level.

Maximum output levels are different depending on RF terminal or Tx/Rx terminal.

Terminal	Maximum output	Minimum output	Output step
Tx/Rx	-7dBm	-125Bm	0.1dB
RF	+6dBm	-125 Bm	0.1dB

(3) BER measurement

Press **SINGLE** or **REPEAT(START/STOP)** to start the measurement. Press **REPEAT(START/STOP)** to stop the current measurement.

BER

Enters into BER (Bit Error Rate) measurement mode.

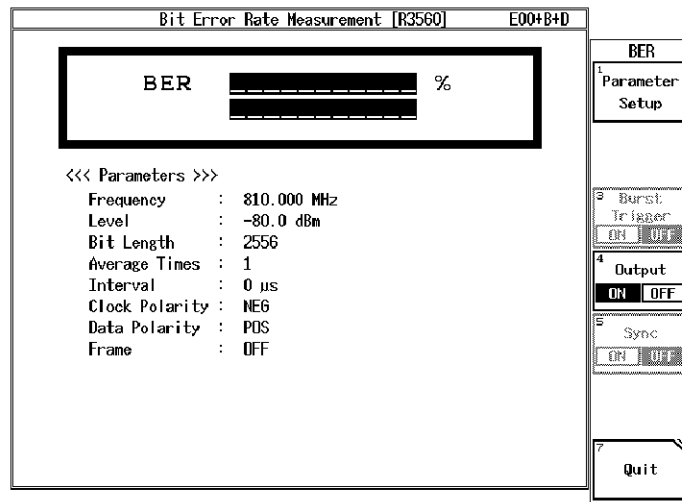

Figure 3-3 BER measurement screen

Parameter Setup

Dialog box for BER measurement parameter setting is displayed to set bit length or average number of times, etc.

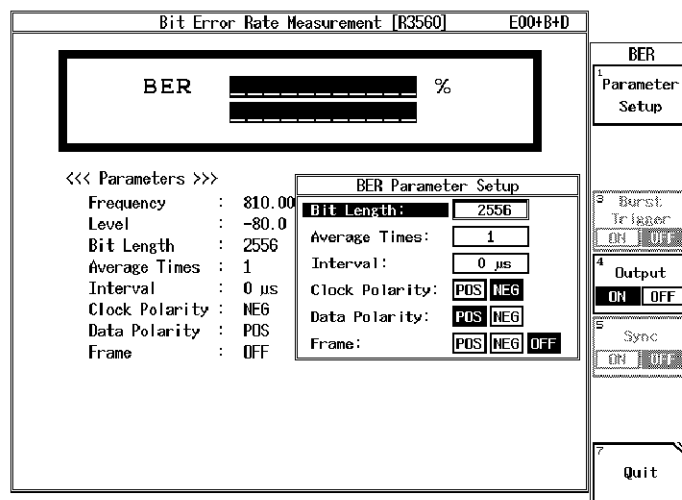

Figure 3-4 Dialog box for BER measurement screen

3.2 Reference

Bit Length

Set BER measurement time with the bit length.
The setting range of the bit length is 1000 to 1000000 bits.

Average Times

Set measurement averaging count.
The setting range of the averaging count is 1 to 32 times.

Interval

Set interval time between receipt of measurement start from R3560 and actual measurement start.
When average measurement is specified, it also can be used as the interval time between the end of the measurement and the start of the next measurement. Refer to R3560 operation manual for details.
The setting range of the interval time is 0.00 to 1.00 second which has steps of 0.01 second (10 ms.).

Clock Polarity

Select from which edge you get data, the rising edge of the signal from BER clock terminal or the falling edge.
POS: Rising
NEG: Falling

Data Polarity

Select if you invert BER DATA terminal data or not.
POS: Positive logic (not invert)
NEG: Negative logic (invert)

Frame Perform the timing control of TCH frame. If you use the TCH frame timing signal that is entered from the FRAME terminal for BER measurement, specify a logic of the TCH frame timing.

OFF: Not use.
POS: Positive logic
NEG: Negative logic

Burst Trigger ON/OFF

Select ON or OFF to make the Burst Trigger function enabled or disabled.

Output ON/OFF

Switches the signal of the output terminal to ON/OFF.

Sync ON/OFF

Switch the synchronization burst output of PHS to ON/OFF.
This is available only on conditions that the system mode is PHS and that the slot pattern is DNT/UPT.
When ON is selected, the synchronization burst frame is output. When OFF is selected, the output of the synchronization burst frame is stopped.

Quit

Quits BER measurement mode.

(4) Receiver sensitivity (Sens) measurement

Press SINGLE or REPEAT(START/STOP) to start the measurement. Press REPEAT(START/STOP) to stop the current measurement.

Sens

Enters into the receiver sensitivity measurement mode.

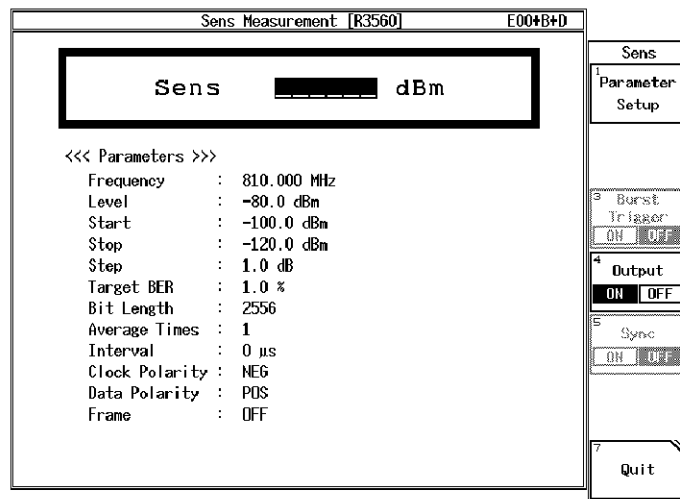

Figure 3-5 Sens measurement screen

Parameter Setup

Displays a dialog box to set the receiver sensitivity measurement parameter and sets output level, etc to start the receiver sensitivity measurement.

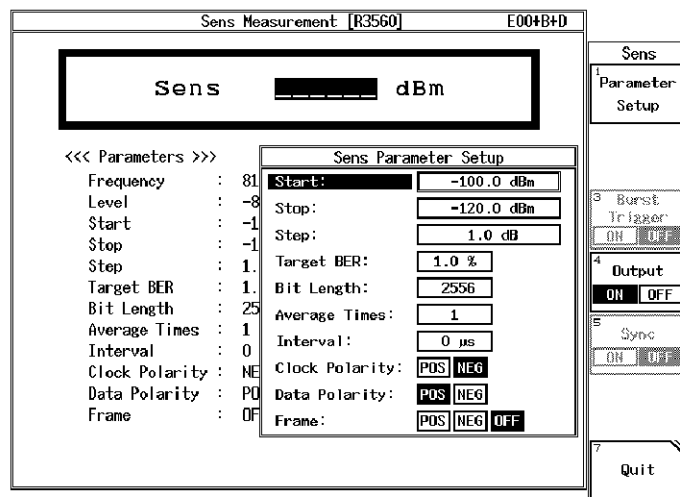

Figure 3-6 Dialog box screen for Sens Parameter setting

3.2 Reference

Start Set output level (the search upper limit value) to start sensitivity measurement.

The relationship between the search upper limit value and the search lower limit value should be;
Search upper limit value > Search lower limit value.

Stop Set output level (the search lower limit value) to end sensitivity measurement.

Step Set the width of output level change.

Target BER

Specify BER point to search. The setting range of the search points is 0% to 5% which has steps of 0.1%.

Bit Length

Set the time for BER measurement with bit length.
The setting range is 1000 to 1000000 bits.

Average Times

Set the averaging times for BER measurement.
The setting of averaging times is between 1 and 32 times.

Interval

Set R3560 interval time for BER measurement.
The setting range is 0.00 to 1.00 s. which has steps of 0.01s. (10 ms.).

Clock Polarity

Select at which edge you get the data for BER measurement, the rising edge of the signal from BER clock terminal or the falling edge.

POS: Rising
NEG: Falling

Data Polarity

Select to invert or not to invert BER DATA terminal data for BER measurement.

POS: Positive logic (not invert)
NEG: Negative logic (invert)

Frame Control the timing of TCH frame for BER measurement.

If you use the TCH frame timing signal that is entered from the FRAME terminal for BER measurement, specify a logic of the TCH frame timing.

OFF: Not use.
POS: Positive logic
NEG: Negative logic

Burst Trigger ON/OFF

Select ON or OFF to make the Burst Trigger function enabled or disabled.

Output ON/OFF

Switches the signal of the output terminal to ON/OFF.

Sync ON/OFF

Switch the synchronization burst output of PHS to ON/OFF.

This is available only on conditions that the system mode is PHS and that the slot pattern is DNT/UPT.

When ON is selected, the synchronization burst frame is output.

When OFF is selected, the output of the synchronization burst frame is stopped.

Quit

Quits the receiver sensitivity measurement mode.

(5) **System mode and slot setting**

Sets R3560 system mode and slot configuration, etc.

Parameter Setup

The dialog box is displayed on the screen to set the system mode and the slot configuration, etc.

* How to operate the dialog-box

The operation to select the set items and set parameters is performed using the data knob and step keys in the same manner as the standard dialog-box in the R3267 Series.

[Burst]	[CC(Hex)]	[SACCH(Hex)]	[Pattern]	[Sync Word]	
Slot1	ON	00	000000	PN15	S1
Slot2	ON	00	000000	PN15	S2
Slot3	ON	00	000000	PN15	S3

Scramble : OFF Scramble Code : 000 [Hex]

Figure 3-7 SETUP setting screen

Mode Set R3560 system mode.
 PDCL: PDC system 800 MHz band
 PDCH: PDC system 1.5 GHz band
 PHS: PHS system

3.2 Reference

Slot Config

Sets slot pattern.

FIL: FILL pattern

DEV: Frame for device evaluation

DNT: Downlink traffic channel

UPT: Uplink traffic channel

DSYNC:

Downlink synchronization burst frame (PHS only)

USYNC:

Uplink synchronization burst frame (PHS only)

Modulation

Switches modulation and non-modulation of the output.

ON: Modulation signal ($\pi/4$ DQPSK)

OFF: Non-modulation signal (cw)

Filter Switches the base band filter.

ROOT NYQUIST:

Root Nyquist filter

NYQUIST:

Nyquist filter

Output Switches the signal output terminal.

TRX: Tx/Rx terminal

RF: RF terminal

Level Unit

Selects the setting of signal level and the display unit.

dBm: Sets the level unit to dBm.

dB μ Vemf: Sets the level unit to dB μ Vemf.

Burst Trigger (*1)

Selects ON or OFF to make the Burst Trigger function enabled or disabled. This setting can be made from the SoftKey menu in the BER/SENS measurement screen.

ON: Enables the Burst Trigger function.

OFF: Disables the Burst Trigger function.

Trig Polarity

Selects POS or NEG to make the rising edge or the falling edge of the input signal of the R3560 Burst Trigger in terminal enabled.

POS: Selects the rising edge.

NEG: Selects the falling edge.

*1: The timing to output the R3560 RF signal is controlled by synchronizing with the input signal of R3560 Burst Trigger in terminal. This function takes effect when the modulation is in the ON state and settings of the system mode and the slot configuration are as shown in Table 3-2 Conditions.

Trigger Delay

Sets the delay from the input signal of the R3560 Burst Trigger in terminal in symbols.

When a signal effective to the Burst Trigger in terminal is gotten, delay can be changed within ± 10 symbols (resolution of 0.1 symbols) based on the time "T" (see Table 3-1 and Figure 3-8) defined according to the system mode and the rate.

Table 3-1 Time defined according to the system mode and the rate

System mode	Rate	Time "T" defined according to the system mode
PDCL/PDCH	FULL	20[ms]
	HALF	40[ms]
PHS		5[ms]

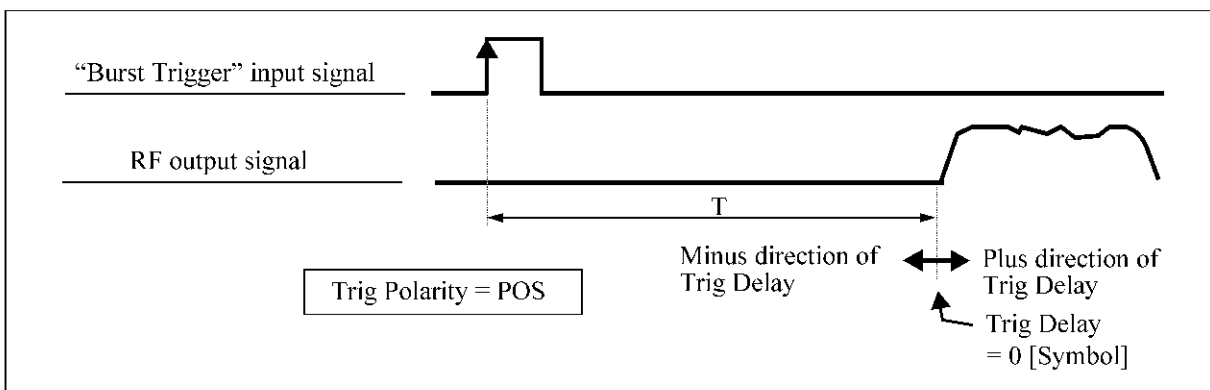

Figure 3-8 Timing of RF signal output vs the Burst Trigger input signal

Table 3-2 Effective setting condition in Burst Trigger functions

System mode	Slot configuration					
	FIL	DEV	DNT	UPT	DSYNC	USYNC
PDCL	×	○	×	○	Not set	
PDCH			○			
PHS			○		○	○

○ : Effective × : Ineffective

3.2 Reference

Slot Setup

The dialog box to set modulation pattern and communication rate in the slot is displayed.

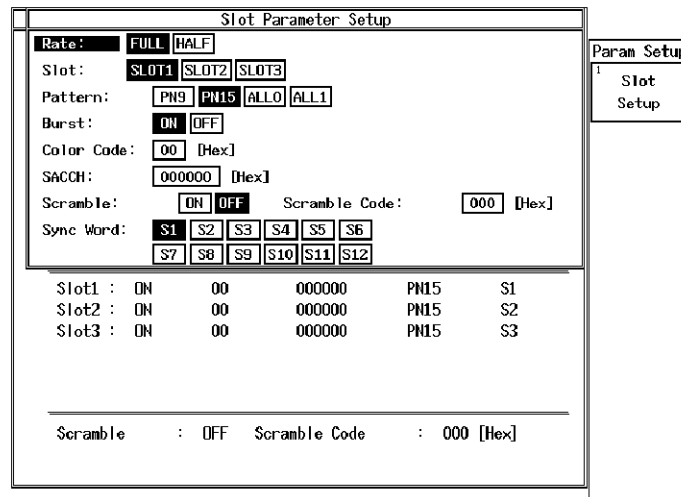

Figure 3-9 SLOT setting screen

- Rate** Switch the communication rate.
The setting can be performed only when the system mode is PDCL/PDCH.
FULL: Full rate
HALF: Half rate
- Slot** Specify to which slot the Pattern, Burst, Color Code, and SACCH are set.
- Pattern** Select a pattern of the user information transmitting channel of traffic channel for PDC, information channel I of traffic channel for PHS, and pseudo random pattern (frame for device evaluation or continuous pseudo random pattern).
PN9: PN9 pattern
PN15: PN15 pattern
ALL0: ALL 0 pattern
ALL1: ALL 1 pattern

Burst (*1)

Switch ON/OFF of the current slot which was selected at Slot.

ON: Sets the slot to ON.

OFF: Sets the slot to OFF.

Color Code (*1, *2)

Set the color code in the slot.

The setting can be performed only when the system mode is PDCL/PDCH.

The setting range is 0 to FF in hexadecimal.

SACCH (*2)

Set slow associated control channel.

The setting can be performed only when the slot configuration is DNT/UPT.

The setting range is as Table 3-3 with hexadecimal.

Table 3-3 SACCH settable range

System mode	Slot configuration	Setting range of SACCH	
		Minimum value	Maximum value
PDCL/PDCH	Downlink traffic channel: DNT Uplink traffic channel: UPT	0 (Hexadecimal) 0 (Hexadecimal)	1FFFFFF (Hexadecimal) 7FFF (Hexadecimal)
PHS	Downlink traffic channel: DNT Uplink traffic channel: UPT	0 (Hexadecimal) 0 (Hexadecimal)	FFFF (Hexadecimal) FFFF (Hexadecimal)

Scramble (*1)

The setting to perform or not to perform scramble control to traffic channel for PDC communication, traffic channel, and synchronization burst for PHS communication.

The ranges of the scramble are different depending on the communication system, uplink/downlink, and so on. Refer to R3560 operation manual for details.

ON: The scramble control is performed.

OFF: The scramble control is not performed.

*1: The setting may be limited depending on the state of the slot configuration. Refer to R3560 Operation Manual Slot Configuration for details.

*2: The input is performed in hexadecimal. The input of A to F in hexadecimal is performed as follows with the shift key.

Input value Operation

A: Shift→0

B: Shift→1

C: Shift→2

D: Shift→3

E: Shift→4

F: Shift→5

3.2 Reference

Scramble Code (*2)

Set scramble pattern.

The setting ranges are different depending on the system mode.

Table 3-4 Scramble pattern setting range

System mode	Setting range	
	Minimum value	Maximum value
PDCL/PDCH	0 (Hexadecimal)	1FF (Hexadecimal)
PHS	0 (Hexadecimal)	3FF (Hexadecimal)

User Scramble

Set to do user scramble or not to do user scramble to the physical slot for communication.

The setting can be performed only when the system mode is PHS.

ON: The user scramble is performed.

OFF: The user scramble is not performed.

User Scramble Code (*2)

Set user scramble pattern to the traffic channel.

The setting range of the user scramble pattern is 0 to FFFF in hexadecimal.

PS (*2) Calling identification pattern is set.

The setting can be performed only when the system mode is PHS and the slot configuration is USYNC/DSYNC.

The setting range is 0 to FFFFFFFF in hexadecimal.

CS (*2) Called identification pattern is set.

The setting can be performed only when the system mode is PHS and the slot configuration is USYNC/DSYNC.

The setting range is 0 to 3FFFFFFFFF in hexadecimal.

*2: The input is performed in hexadecimal. The input of A to F in hexadecimal is performed as follows with the shift key.

Input value	Operation
A:	Shift → 0
B:	Shift → 1
C:	Shift → 2
D:	Shift → 3
E:	Shift → 4
F:	Shift → 5

Sync Word

Specify the slot and change the synchronization word.
 This command can be set when the system mode is PDCL or PDCH and the slot configuration is UPT or DNT.
 Setting value of the synchronization word is shown in Table 3-5.

Table 3-5 Setting value of the synchronization word

Sync word No.	20-bit synchronization word pattern (hexadecimal)	
	DNT	UPT
S1	87A4B	785B4
S2	9D236	62DC9
S3	81D75	7E28A
S4	A94EA	56B15
S5	5164C	AE9B3
S6	4D9DE	B2621
S7	31BAF	CE450
S8	1E56F	E1A90
S9	E712C	18ED3
S10	FBC1F	043E0
S11	8279E	7D861
S12	98908	676F7

Note: S1 to S12 in the table correspond to the 20-bit synchronization word pattern numbers of STD-27.

(6) Output ON/OFF setting

Output ON/OFF

Switches the signal of the output terminal to ON/OFF.

3.2 Reference

(7) Saving

Saves all currently-set conditions to the R3560 backup memory according to the specified memory number.

Save

The save operation screen is displayed. To select the memory number and to execute data saving, use a knob.

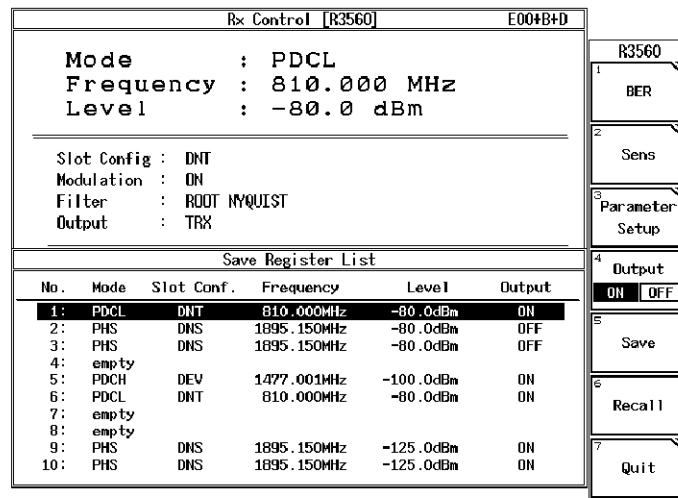

Figure 3-10 Save operation screen

In the save operation screen, the major settings inside the R3560 backup memory are displayed.

Details on the settings are explained below.

- No:** The memory number is displayed.
- Mode:** The set system mode is displayed.
- Slot conf:** The set pattern of the slot is displayed.
- Frequency:** The set output frequency is displayed. (The unit is fixed to MHz.)
- Level:** The set output level is displayed. (The unit is fixed to dBm.)
- Output:** The set condition (ON or OFF) of the data output is displayed.

NOTE: When empty is displayed after the column of No., it shows that no condition is saved to that memory number.

(8) Recalling

Re-sets all set conditions of the memory according to the specified memory number of the R3560 backup memory.

Recall

The recall operation screen is displayed. To select the memory number and to execute data recalling, use a knob.

The explanation of the recall operation screen is the same as that of the save operation screen. Refer to the explanation in the above (a).

(9) Measurement error message displaying function

With this function, measurement error messages in the Bit Error Rate measurement (hereafter called BER measurement) and the receiver sensitivity measurement (hereafter called SENS measurement) are displayed.

The cause that the BER or the SENS measurement was not properly executed is displayed. The measurement error messages and details on errors are as follows.

1. Sync error

Synchronization cannot be taken with the data input from the DATA terminal of the BER measurement.

2. Clock error

A clock is not input to the clock terminal of the BER measurement.

3. SensPoint is not found

The point of BER (Target BER) specified in the Sens measurement is not found. (This message is output only in the Sens measurement.)

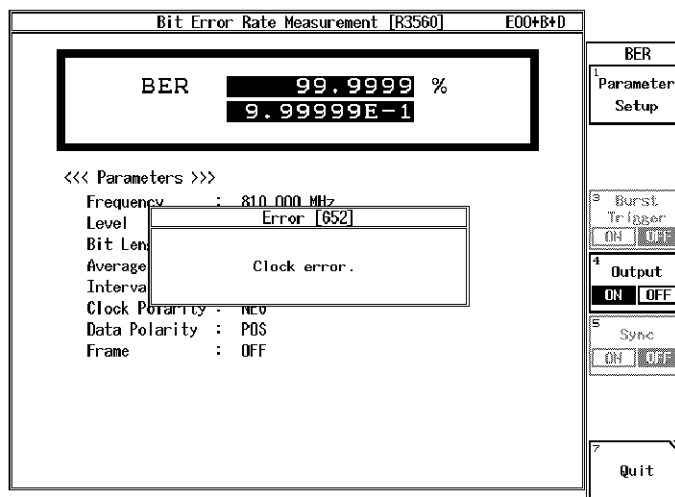

Figure 3-11 BER measurement screen (in occurrence of Sync error)

3.3 Example of the measurement (BER measurement)

3.3 Example of the measurement (BER measurement)

Here explains the outline of the operation with a measurement example of a receiver which has a control mode to receive physical channel for down communication.

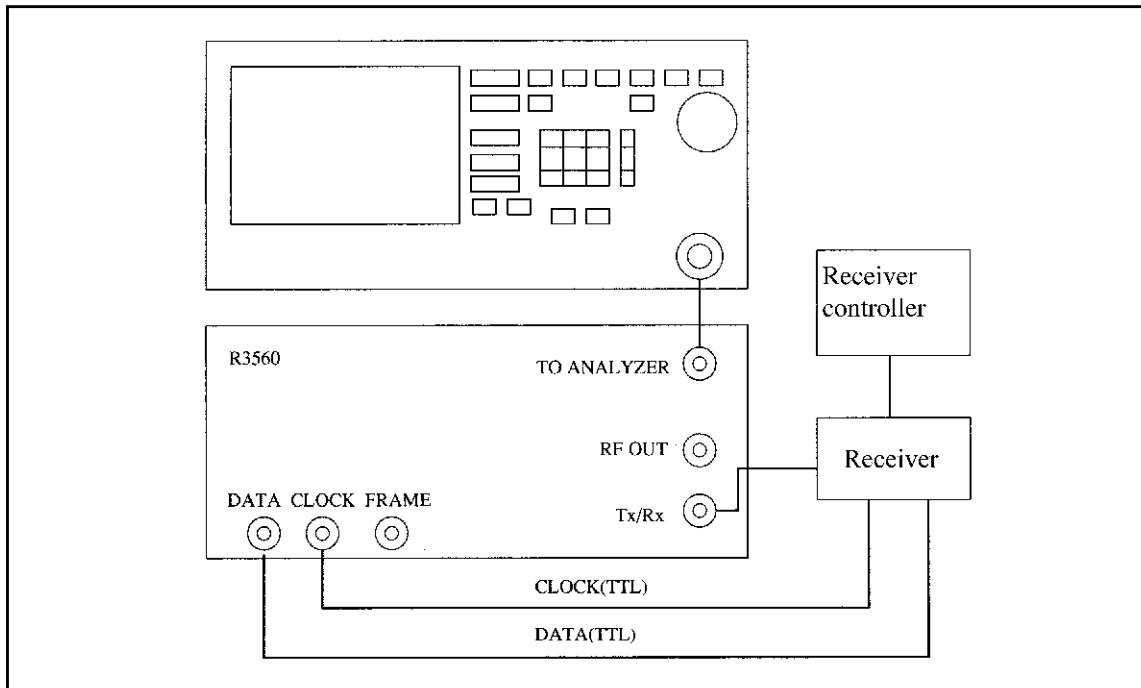

Figure 3-12 BER measurement connection

Follow the procedure below

1. Connect as shown in Figure 3-12.
2. Pressing **SETUP** displays dialog box for system mode and slot configuration setting.
 In this box, the selection of each parameter setting value with the data knob and the movement between parameters with the step key can be performed.
 After selecting 1 parameter with the data knob, in order to define the setting, press the data knob or **Hz**.
 Set system mode by using this dialog box. Set slot configuration in downlink traffic channel (DNT) as well.
3. Pressing **SLOT** displays dialog box for the setting in the slot.
 By operating this dialog box, slot No., slot TCH pattern, PN 9 pattern, etc. for the measurement are set. Set SACCH, scramble, etc. as needed.
 After the setting in the slot, press **return** twice and return the menu to the top step of **Rx Test** menu.
4. Press **FREQ** and set the frequency to test R3560 frequency.

3.3 Example of the measurement (BER measurement)

5. Press **LEVEL** and set R3560 output level to a suitable level for the receiver.
6. Set the receiver in a receivable mode using the receiving controller.
7. Pressing **BER** and **BER Param** displays dialog box for BER counter setting. Set demodulation data, polarity of demodulation clock, average times, interval, etc.
8. Pressing **REPEAT** or **SINGLE** starts the measurement.

4 HOW TO OPERATE THE R3561

This chapter describes all key functions of the R3561.

4.1 Outline

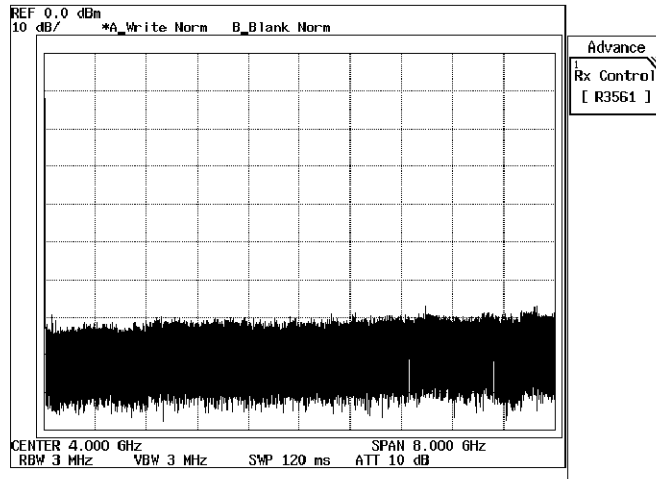

Figure 4-1 Initial screen

The operation menu of R3561 is placed under the **ADVANCE**.

Press **ADVANCE** and **Rx Control [R3561]**, R3267 Series becomes R3561 control mode and displays Initial screen shown in Figure 4-2 to set and measure R3561.

In this mode, operation with only soft-key or dialog box becomes effective except **FREQ** and **LEVEL**. The operation with **SPAN** and so on which can be used in ordinary operation mode cannot be performed. In order to return to the ordinary operation mode, press **POWER**, **UTIL**, **TRANSIENT** or **Quit**.

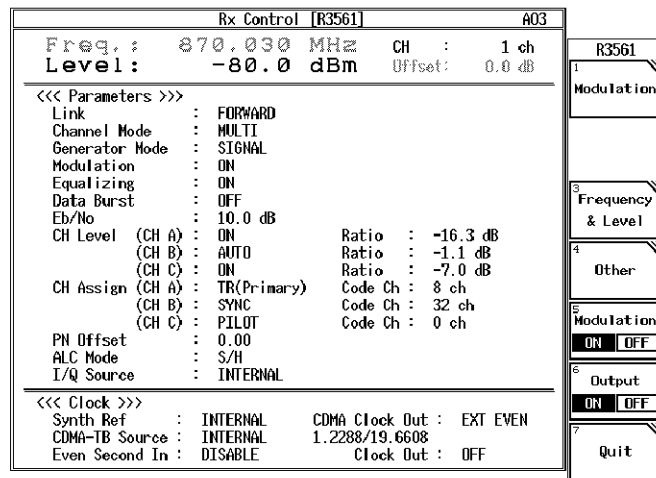

Figure 4-2 Initial Screen (R3561 mode)

4.2 Reference

4.2 Reference

This section describes the functions of all panel and soft keys.

- Menu Index: Use this index as a key index to Chapter 4.
- Menu Map: Shows a list of hierarchical menus on a panel key basis.
- Functional Description: Explains the functions of the panel and soft keys.

The panel keys are arranged in alphabetical order.

4.2.1 Menu Index

This menu index is used to easily find the keys described in Chapter 4.

<u>Operation Key</u>	<u>Pages</u>	<u>Operation Key</u>	<u>Pages</u>
1.2288/19.6608 Clock Out.....	4-5	Frequency & Level	4-4, 4-11
10MHz Ref Adj.....	4-5	Frequency Setup.....	4-5, 4-11
ALC Mode	4-5, 4-12	I/Q Source	4-4, 4-5, 4-8
AWGN	4-5, 4-15	LEVEL.....	4-6
AWGN Cal Corr ON/OFF.....	4-5, 4-15	Menu Assistant ON/OFF	4-4, 4-9
CDMA Clock Out.....	4-5	Menu Assistant Setup	4-4, 4-9
CDMA-TB Source	4-5	Level Offset	4-5, 4-12
CH A	4-4, 4-5, 4-7	Level Ratio.....	4-4, 4-5, 4-7
CH B	4-4, 4-5, 4-7	Level Setup	4-5, 4-11
CH C	4-4, 4-5, 4-7	Link	4-4, 4-5, 4-6
CH Start Freq.	4-5, 4-11	Modulation	4-4, 4-6, 4-12
CH Start No.....	4-5, 4-11	Modulation ON/OFF.....	4-4, 4-5, 4-10, 4-12, 4-16
CH Step Freq.....	4-5, 4-11	Modulator.....	4-5, 4-15
Cal/Test	4-5, 4-14	Modulator Cal Corr ON/OFF.....	4-5, 4-15
Channel Assign	4-4, 4-8	Offset Value	4-5, 4-12
Channel Mode.....	4-4, 4-5, 4-7	Other	4-4, 4-13
Clock Setup	4-5, 4-13	Output ON/OFF	4-4, 4-5, 4-10, 4-12, 4-17
Code Channel.....	4-4, 4-9	PN Offset	4-4, 4-5, 4-8
Data Burst	4-4, 4-5, 4-7	Preset.....	4-5, 4-16
Data Rate.....	4-4, 4-9	Quit	4-4
Eb/No [CH A/No]	4-4, 4-5, 4-7	Save.....	4-5, 4-16
Equalizing	4-4, 4-5, 4-7	Save Register List	4-5
Even Second In	4-5	Recall	4-5, 4-16
FREQ	4-6	Recall Register List.....	4-5
General Setup.....	4-4, 4-6	Self Test	4-5, 4-15
Generator Mode	4-4, 4-5, 4-7	Step Size.....	4-5, 4-11, 4-12
Frame A Setup	4-4, 4-8	Rx Control [R3561]	4-4
Frame B Setup.....	4-4, 4-8		
Freq Input.....	4-5, 4-11		

Synth Ref	4-5
Unit	4-5, 4-12
Upper Limit	4-5, 4-12
Traffic PRBS	4-4, 4-9

4.2 Reference

4.2.2 Menu Map

A list of soft menus, which are under the **ADVANCE** key, used with the R3561 are shown below.

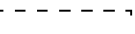
NOTE:  Represents a panel key.
 Represents a dialog box.
 Unless otherwise noted, the soft menus are shown.

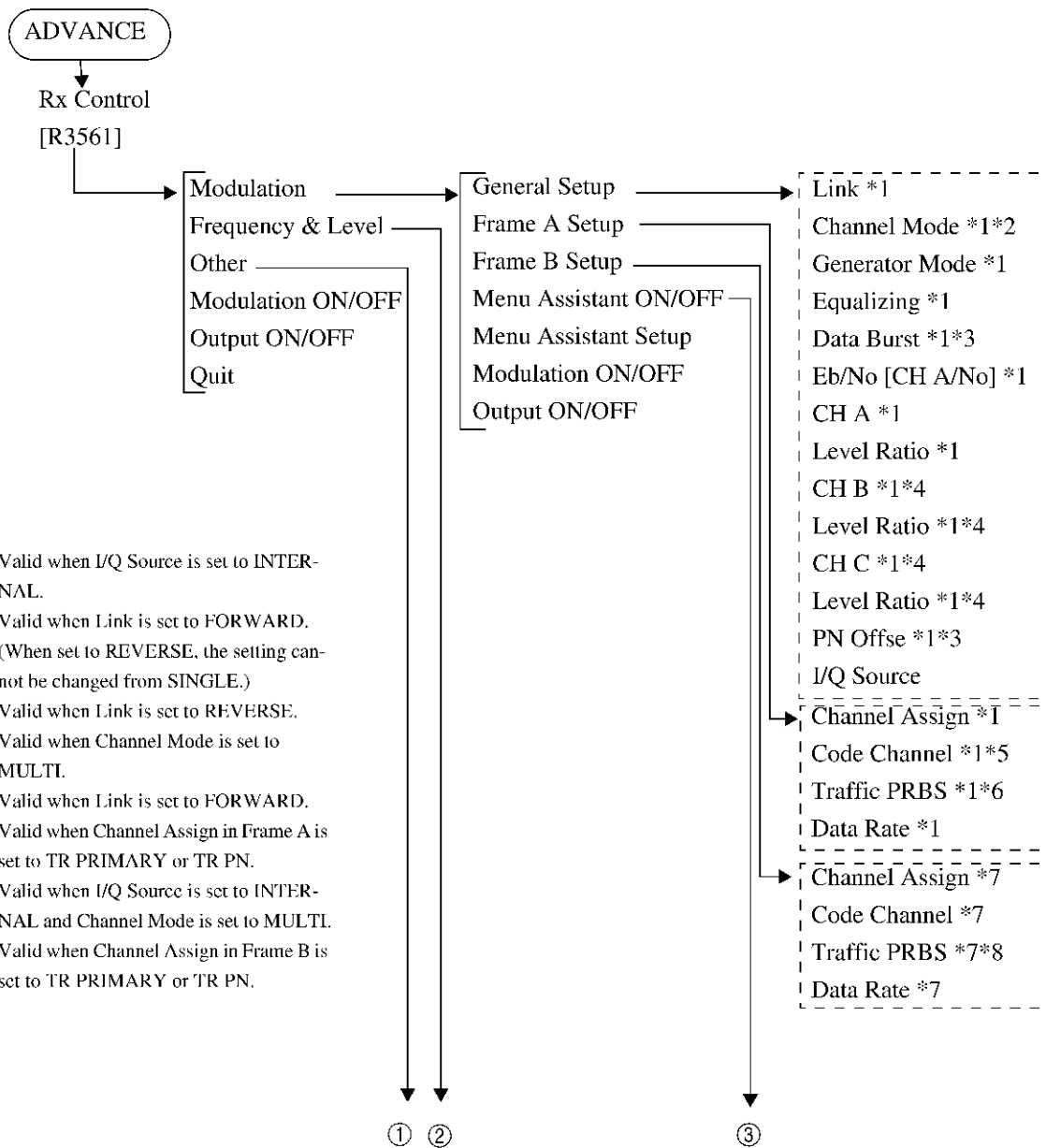

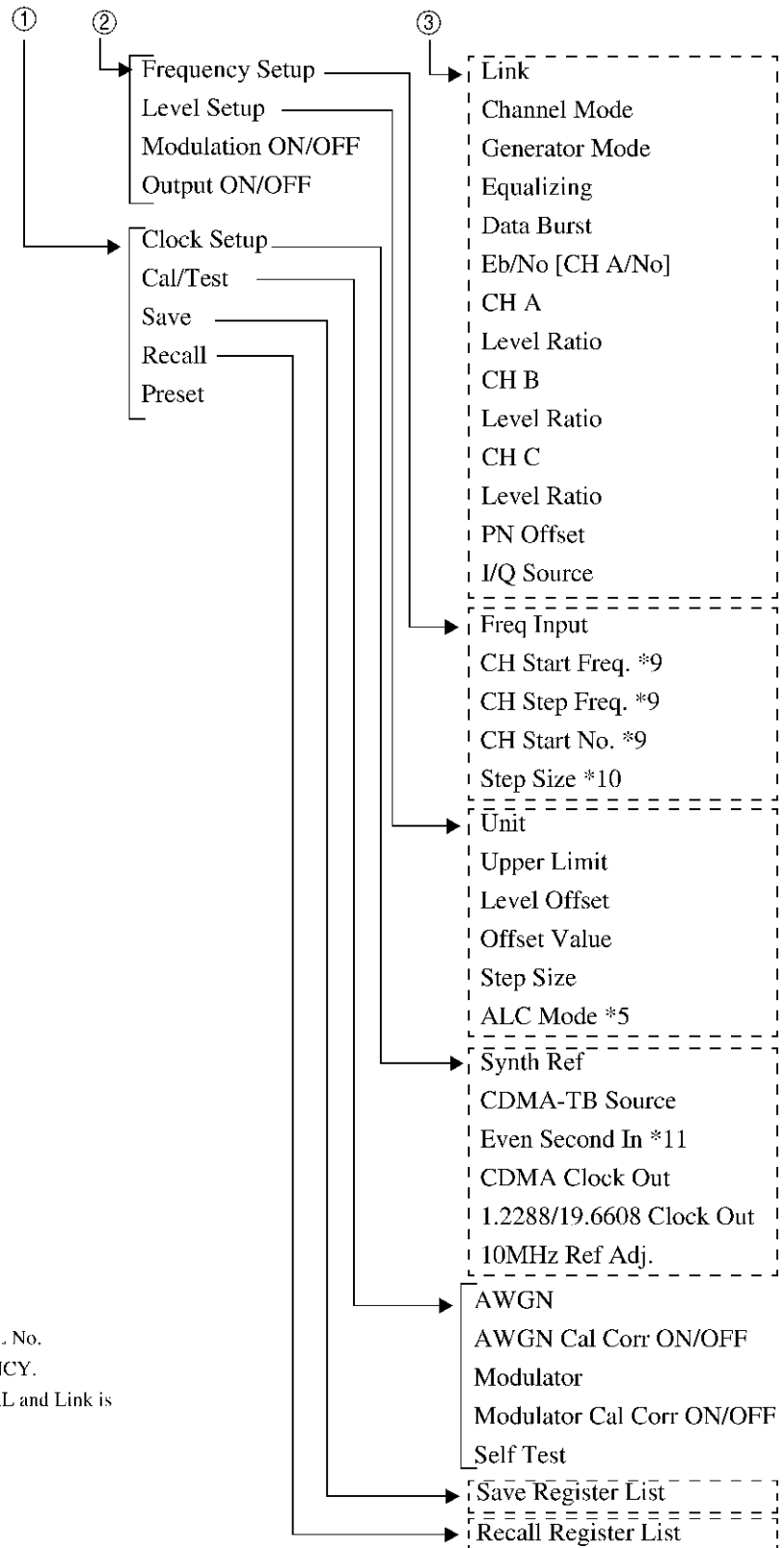

*9 Valid when Freq Input is set to CHANNEL No.
 *10 Valid when Freq Input is set to FREQUENCY.
 *11 Valid when I/Q Source is set to INTERNAL and Link is set to REVERSE.

4.2 Reference

4.2.3 Functional Description

- (1) Setting the output frequency

FREQ

A window prompting numeric values is displayed.
 Sets the output frequency.
 Use the up or down keys, the data knob and the numeric keys to enter data.

- (2) Setting the output level

LEVEL

A window prompting numeric values is displayed.
 Used to set the output level.
 Use the up or down keys, the data knob and the numeric keys to enter data.

- (3) Setting the modulation

Modulation

Displays the menu used with the modulation function.
 When *return* is pressed, the screen display returns to the initial screen.

General Setup

The display box used to set general items such as Link and Channel mode is displayed on the screen.

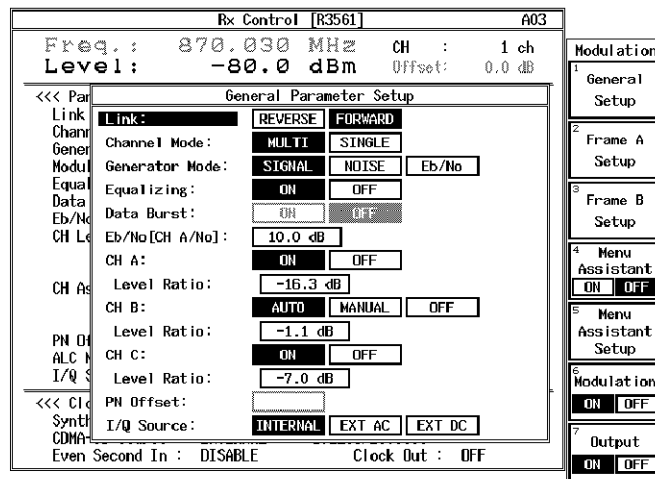

Figure 4-3 General Dialog Screen

Link

Specifies the Link-Direction of the signals used in the R3561.
REVERSE:

Sends signals from the Mobil station to the Base station. The modulation method is OQPSK.

FORWARD:

Sends signals from the Base station to the Mobil station. The modulation method is OQPSK.

- Channel Mode** Selects the base band channel multiplexing.
When in the Reverse link, only SINGLE mode can be used.
MULT: Multiplexed output from channels A, B and C is obtained.
SINGLE: Outputs channel A only.
- Generator Mode**
Selects the signal input to the I Q-Modulator in the MOD/ CONV block.
SIGNAL: Selects CDMA signals.
NOISE: Selects an AWGN output with a bandwidth of 2 MHz.
Eb/Nt (No) :
Selects CDMA signal superimposed on AWGN signal.
The ratio of channel A signal to the AWGN output level can be changed by Eb/NO [CH A/No].

NOTE: *AWGN calibration must be performed to select the generator mode Eb/Nt(No).
When an IQ Sequence is set to EXTAC or EXTDC, only SIGNAL is selected for the generator mode.*

- Equalizing** Toggles the Equalizing Filter on or off. This setting is automatically toggled when the setting for Link is changed.
- Data Burst** Toggles the Data burst on or off.
- Eb/No [CH A/No]**
Sets the value of Eb/Nt(No) for channel A. This setting is valid when the Generator mode is set to Eb/Nt(No).
- CH A**
- CH B**
- CH C** This setting is valid when the Channel mode is set to MULTI, and channels A and C can set this function on or off. Channel B can select AUTO, MANUAL or OFF. When set to AUTO, channel B level is automatically set so that the sum of the levels (of channels A, B and C) is 0 (dB).
When set to MANUAL, an arbitrary value can be specified by the Channel Level Ratio.
- Level Ratio** This setting is valid when the channel mode is set to MULTI. Each channel level is set in relation to the sum of the levels (of channels A, B and C).

NOTE: *A ratio is obtained when channel B is set to AUTO for the Channel ON/OFF.*

4.2 Reference

- PN Offset** Sets the PN sequence offset value.
1PN Offset = 64 chips
- I/Q Source** Selects the signal to be input to the IQ-Modulator.
INTERNAL: Connects the internal base band IQ signal.
EXT AC: Couples the external IQ signal with an AC coupling.
EXT DC: Couples the external IQ signal with a DC coupling.

CAUTION:An alarm will sound when the IQ Source is selected to EXT DC and its input level exceeds the upper limit. Lower the input level below the upper limit immediately

WARNING:There is a possibility that this instrument will be damaged if an input level at the EXTERNAL IQ input terminal I exceeds the upper limit. Be sure to use within the specified range.

Frame A Setup
Frame B Setup

Sets frame details for channels A and B.

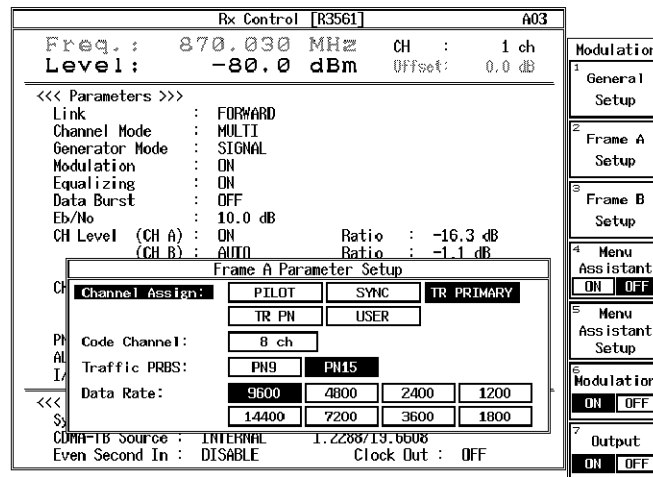

Figure 4-4 Frame A Dialog Box Screen

Channel Assign Selects channel signals for channels A and B.

Table 4-1 Channel Signals

Channel Signal Type	Description
PILOT	When LINK is set to FORWARD, this becomes the PILOT channel based on the TIA/EAI IS95 standards.
ZEROS (ZEROES)	When LINK is set to REVERSE, the data pattern is DATA ALL0.
SYNC	This is enabled only when the LINK is set to FORWARD. This becomes the SYNC channel based on the TIA/EAI IS95 standard.
TR PRIMARY (TRAFFIC PRI- MARY)	Selects the frame which inserts PRBS into the Primary Traffic section within Information bits in the Traffic channel frame.
TR PN (TRAFFIC PN)	Selects the frame which inserts PRBS into all of the Information bits in the Traffic channel frame.
USER	Downloads data from the outside into the User Defined Buffer in this instrument, and outputs this data. For detailed information on how to use USER, refer to User Define Buffer Functions in the R3561 Operation manual.

Code Channel This function selects the type of code channel for channels A and B. Orthogonal code spreading is performed for each channel using the Walsh function corresponding to the selected code channel.

The code channel is always set to 0 (zero) when the channel assignment is set to PILOT. When set to SYNC, the code channel is set to 32.

Traffic PRBS This function selects the PRBS inserted into Information Bits in the Traffic channel frame.

PN9: Pattern based on ITU-T V5.2

PN15: Pattern based on ITU-T 0.151

Data Rate Selects the data rate for channels A and B.

Menu Assistant ON/OFF

When this key is turned on, set items for the general dialog box are edited by Edit Menu.

Menu Assistant Setup

Displays the screen where set items used in the General dialog box are edited.

4.2 Reference

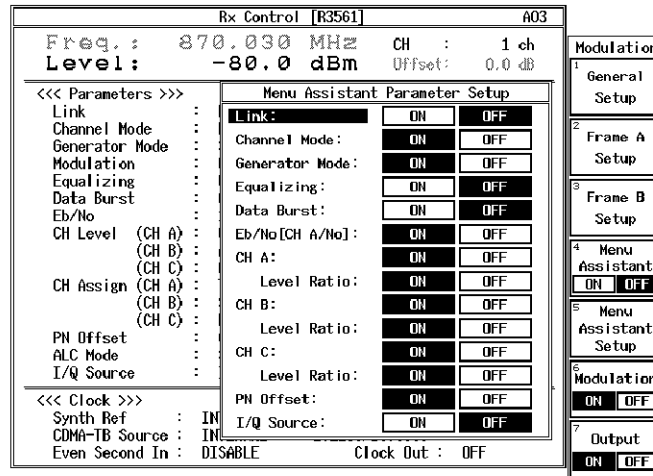

Figure 4-5 Edit Menu Dialog Box Screen

The items you set to ON (on this screen) can be changed on the general dialog box screen shown in Figure 4-3. If you set unnecessary items to OFF, these items will be skipped when operating the step keys.

It is possible to simplify the operation using this method for specific applications. **Menu Ass. ON/OFF**, however, must be turned on to enable the Edit menu.

Modulation ON/OFF

Toggles the modulation on or off.

Output ON/OFF

Toggles the output signal on or off.

- (4) Setting the output frequency and output level

Frequency & Level

A dialog box related to frequency and level settings will be displayed.

Frequency Setup

A dialog box related to frequency parameter settings will be displayed.

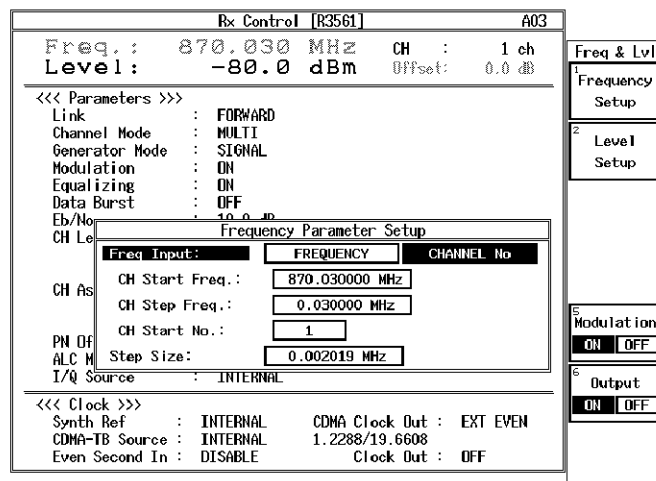

Figure 4-6 Freq Para. Dialog Screen

Freq Input

Selects the frequency entry mode.

FREQUENCY:

Directly enters a frequency value.

CHANNEL No:

Enters a channel number.

CH Start Freq. Sets the channel start frequency.

CH Step Freq. Sets the channel spacing.

CH Start No. Sets the channel start number.

Step Size Sets a step value of the up or down keys.

When *return* is pressed, the screen display returns to the initial screen.

Level Setup

A dialog box to set parameters associated with the output level is displayed.

4.2 Reference

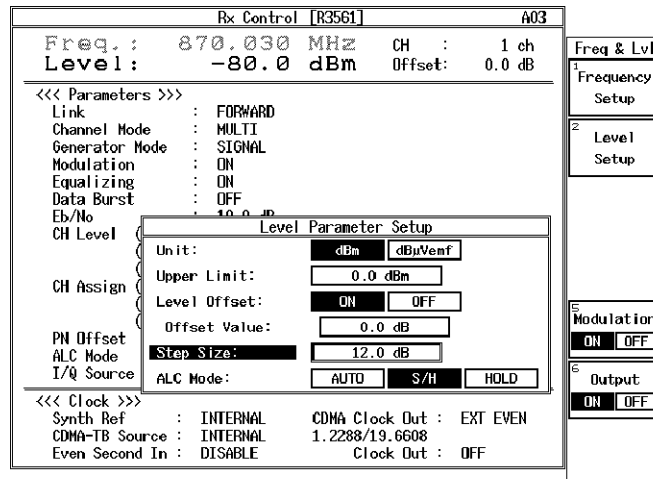

Figure 4-7 Level Para. Dialog Screen

- Unit** Selects the unit to display or enter the data.
- Upper Limit** Sets the upper limit.
- Level Offset** Toggles the level offset addition function on or off.
- Offset Value** Sets the level offset value.
- Step Size** Sets the up or down keys step value.
- ALC Mode** Selects the ALC operating mode.
Automatically selects the optimum operating mode depending on the R3561 settings. (For details, refer to the R3561 Operation manual.)
 - AUTO: Normal ALC
 - S/H: Sample and hold using the reference modulation pattern.
 - HOLD: ALC voltage hold when the reference modulation pattern is used.

CAUTION: When not set to the optimum operation mode, the output from the RF OUT terminal may deviate from the target value.

Modulation ON/OFF
Toggles the modulation on or off.

Output ON/OFF
Toggles the output signal on or off.

When **return** is pressed, the screen display returns to the initial screen.

* How to operate the dialog-box

The operation to select the set items and set parameters is performed using the data knob and step keys in the same manner as the standard dialog-box in the R3267 Series.

(5) Others

Using this screen, other functions can be set.

Other

Furthermore, *Preset*, *Clock Setup* and so on are displayed.

When *return* is pressed, the screen display returns to the initial screen.

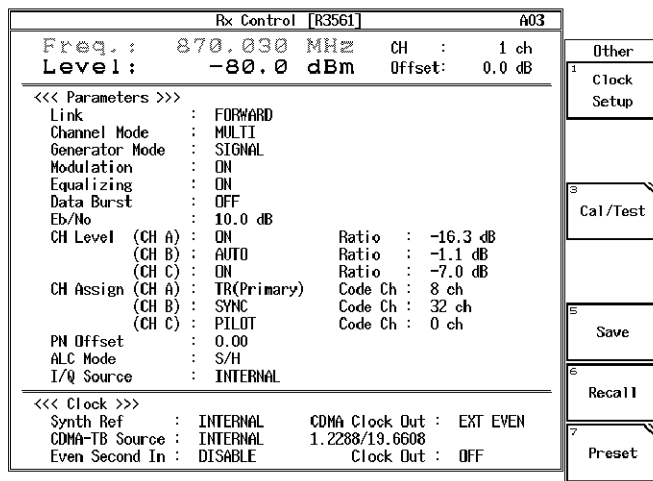

Figure 4-8 Other Screen

Clock Setup

The dialog box which sets various clock signals is displayed.

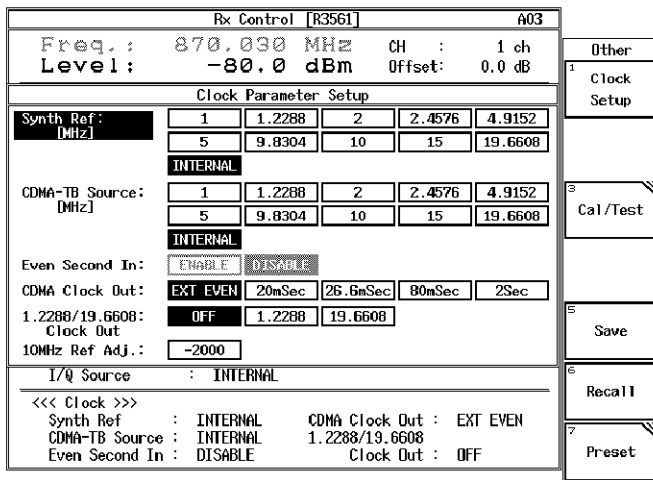

Figure 4-9 Clock Dialog Box Screen

4.2 Reference

Synth Ref Selects the reference frequency of the signal which is output from the SYNTH REF IN terminal and input to the RF synthesizer reference circuit. When INTERNAL is selected, however, the internal reference oscillator signal is input to the RF synthesizer reference circuit.

CDMA-TB Source Selects the reference frequency of the signal which is output from the CDMA TIMEBASE IN terminal and input to the CDMA TIMEBASE reference circuit. When INTERNAL is selected, however, the internal reference oscillator signal is input to the CDMA TIMEBASE reference circuit.

EvenSecond In Specifies whether or not the R3561 base band block functions in sync with the signal from EVENSEC/SYNC IN connector on the front panel.

CDMA Clock Out Selects the CDMA frame clock signal to be output from the CDMA CLOCK OUT terminal.

Table 4-2 Types of CDMA Frame Clock

CDMA Frame Clock	Description
EVEN SECOND IN	Outputs the signal that is input to the EVEN SEC/ SYNC IN terminal. This output is obtained only when the input signal is applied to the EVEN SEC/ SYNC IN terminal.
2 s 80 ms 26.6 ms 20 ms	Outputs the clock signal in the base band block of this instrument.

1.2288/19.6608 Clock Out Selects the signal to be output from the PN CHIP OUT terminal.

10 MHz Ref Adj. Sets a frequency of the internal reference oscillator and corrects the frequency deviation due to the variation of time. The factory-shipped setting is 0, and its range is between -2000 and +2000. These values represent the variable range, but not the frequency range.

Cal/Test Switches the screen display to set or select each function of the R3561 calibration and self-test. When *return* is pressed, the screen display returns to the initial screen.

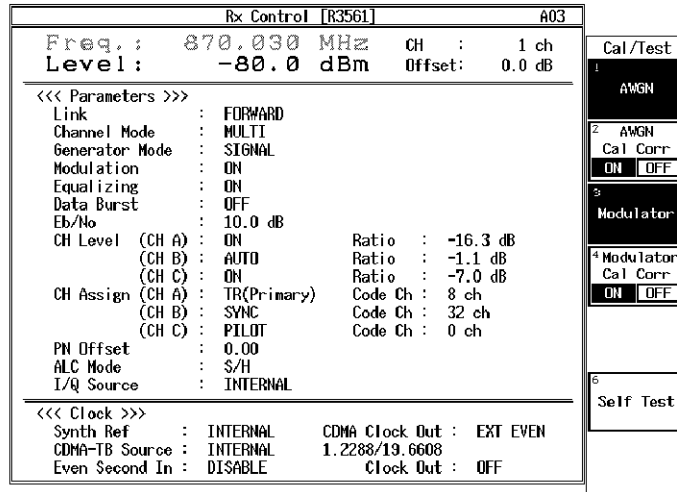

Figure 4-10 Cal/Self Test Screen

AWGN

Calibrates the AWGN level and CDMA signal level.

When the generator mode is selected to "Eb/Nt(Eb/No)", a calibration is required.

CAUTION:It takes 10 to 30 seconds to perform the calibration.

When an abnormal condition is detected during calibration, an error message will be displayed and the calibration will be terminated.

AWGN Cal Corr ON/OFF

Specifies whether or not to use the correction data obtained in the AWGN calibration.

Modulator

The IQ-Modulator balance is calibrated.

CAUTION:It takes 10 to 30 seconds to perform the calibration.

When an abnormal condition is detected during calibration, an error message will be displayed and the calibration will be terminated.

Modulator Cal Corr ON/OFF

Specifies whether or not to use the correction data obtained in the Modulator calibration.

Self Test

This function performs a self-test for each block of this instrument. The POWER, REMOTE and SYNTH UNLOCK lamps are turned on during the test. An alarm will sound when the self-test is complete.

When the self-test is finished, the instrument will revert to its initial state.

4.2 Reference

When the self-test detects an error, an error message and the corresponding error code will be displayed with the POWER, REMOTE and SYNTH UNLOCK lights lit at the same time (for more detailed information on error codes, refer to the R3561 Operation manual). Contact the nearest ADVANTEST Field Office or representative.

Save

Saves the currently set value in the R3561 back-up memory. Pressing this key displays the contents of the R3561 back-up memory (see Figure 4-11). To save the current setting in the back-up memory, press the data knob or the **ENTER** after selecting the file number using the data knob. A maximum of 10 settings can be saved in the back-up memory. Pressing **RETURN** returns the screen display to the Other screen.

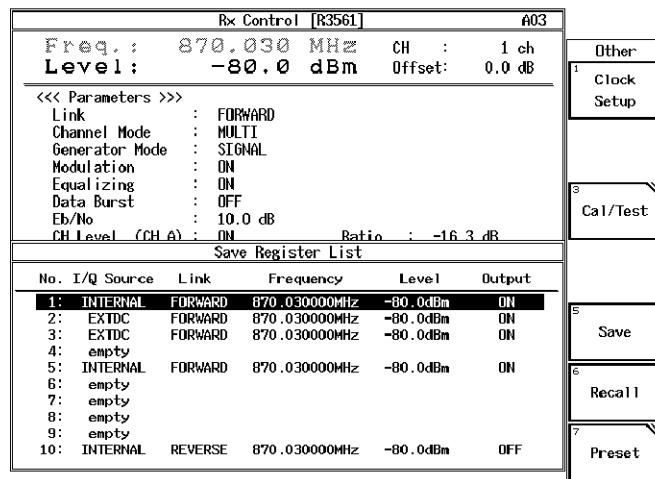

Figure 4-11 Save/Recall Display Screen

Recall

This key is used to read a value saved in the R3561 back-up memory and to set the instrument using this value. Pressing this key displays the contents of the R3561 back-up memory (see Figure 4-9). To read and reset the contents of the back-up memory, press the data knob or the **ENTER** after selecting the file number using the data knob. Pressing **RETURN** returns the screen display to the Other screen.

Preset

Initialize the following sections of the R3561: the frequency, RF level, modulation, frame and input/output blocks. The settings of the other sections will not be reset to the factory defaults. Table 4-3 shows set or selected values after the preset.

(6) Setting the Modulation

Modulation ON/OFF

Toggles the modulation on or off.

- (7) Setting the Output level

Output ON/OFF

Toggles the output signal on or off

4.2.4 Preset Values**Table 4-3 Set Values when Preset (1 of 4)**

Section	Item to Be Set	Channel	Set value/Selected value
Output frequency	Frequency input mode		Direct input mode
	Output frequency		870.03 MHz
	Output channel		1
	Channel start number		1
	Channel spacing		30 kHz
	Start frequency		870.03 MHz
RF level	Output level		-80.0 dBm
	Output level upper limit value		0.0 dBm
	Output level offset ON/OFF		OFF
	Output level offset value		0.0 dB
	Output ON/OFF		ON
	ALC mode		SAMPLE&HOLD

4.2 Reference

Table 4-3 Set Values when Preset (2 of 4)

Section	Item to Be Set	Channel	Set value/Selected value	
Modulation	Modulation ON/OFF		ON	
	Link		FORWARD	
	Channel mode		MULTI	
	Generator mode		SIGNAL ONLY	
	Equalizing Filter ON/OFF		ON	
	Data burst		OFF	
	Eb/No (Eb/Nt) value		10.0 dB	
	Channel ON/OFF		A	ON
			B	AUTO
			C	ON
	Channel level		A	-16.3 dB
			B	-1.1 dB
			C	-7.0 dB
	PN Offset value			0.00
	IQ source value			INTERNAL

Table 4-3 Set Values when Preset (3 of 4)

Section	Item to Be Set	Channel	Set value/Selected value
Frame	Channel assignment	A	TRAFFIC PRIMARY
		B	SYNC
		C	PILOT
	Channel code	A	8
		B	32
		C	0
	Traffic PRBS	A	PN15
		B	PN15
		C	
	Data rate	A	9600bps
		B	1200bps
		C	***
	Start frame number specification*1	A	1
		B	
		C	
	Repetitive frame number specification*1	A	600
		B	
		C	
	Frame number specification		***
	Frame data		***

4.2 Reference

Table 4-3 Set Values when Preset (4 of 4)

Section	Item to Be Set	Channel	Set value/Selected value
Input/Output	EVEN SEC/SYNC IN		DISABLE
	CDMA CLOCK OUT		EVEN SECOND IN
	CDMA TIMEBASE OUT		OFF
	Synthe Reference IN		INTERNAL
	CDMA TIMEBASE IN		INTERNAL

*1 : Factory-shipped set value. This value is not set even if the preset is performed after changing the set value.

*** : Cannot be set or this value is pending.

5 HOW TO OPERATE THE R3562

This chapter describes all key functions of the R3562.

5.1 Outline

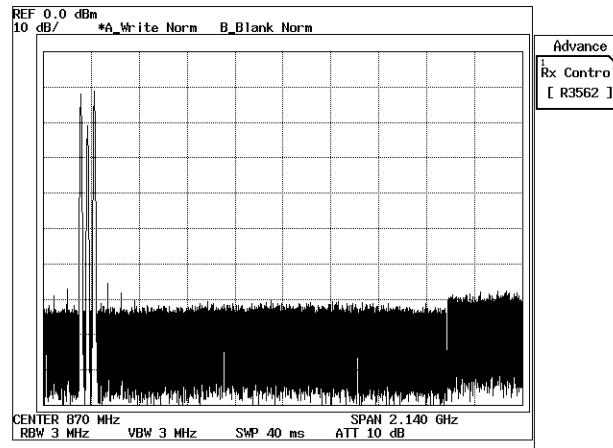

Figure 5-1 Initial Screen (For the R3562 Standard Configuration)

The operation menu of R3562 is placed under the **ADVANCE**.

Press **ADVANCE** and **Rx Control [R3562]**, R3267 Series becomes R3562 control mode and displays the screen shown in Figure 5-3 to set and measure R3562.

In this mode, operation with only soft-key or dialog box becomes effective except **FREQ** and **LEVEL**. The operation with **SPAN** and so on which can be used in ordinary operation mode cannot be performed. In order to return to the ordinary operation mode, press **POWER**, **UTIL**, **TRANSIENT** or **Quit**.

5.1 Outline

[Setting up the communication system]

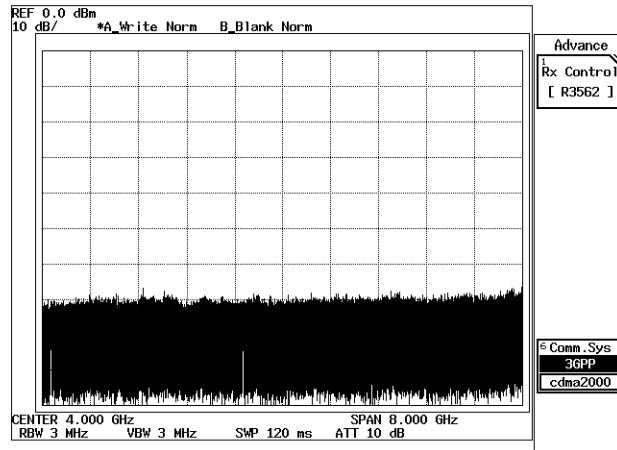

Figure 5-2 Initial Screen (with the R3562 OPT 65 Installed)

If OPT65 is installed in the R3562, the R3562 communication system must always be set to the 3GPP mode. When the Comm.sys key on the Initial screen is set to cdma2000 (highlighted) (Figure 5-2), a mode is not set correctly.

Use the procedure shown below to switch the communication system:

1. Press the Comm.sys key to set 3GPP (highlighted).
2. Turn the R3562 power switch off, and then on again.

NOTE: Always perform steps 1 and 2 to change the communication system (performing step 1 only does not complete the operation).

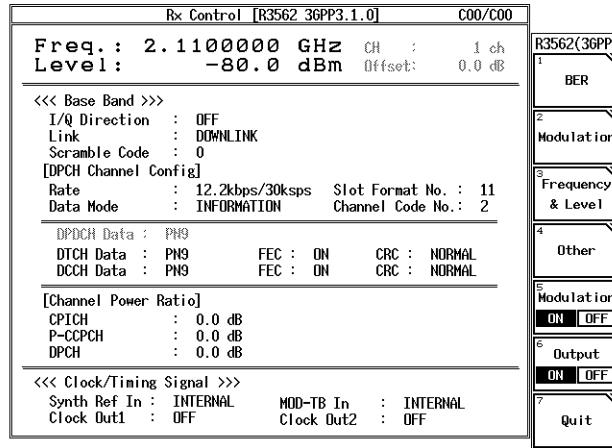

Figure 5-3 R3562 Control Main Screen (3GPP)

5.2 Reference

5.2 Reference

This chapter describes the functions of all panel and soft keys.

- Menu Index: Use this index as a key index to Chapter 5.
- Menu Map: Shows a list of hierarchical menus on a panel key basis.
- Functional Description: Explains the functions of the panel and soft keys.

The panel keys are arranged in alphabetical order.

5.2.1 Menu Index

This menu index is used to easily find the keys described in Chapter 5.

<u>Operation Key</u>	<u>Pages</u>	<u>Operation Key</u>	<u>Pages</u>
10MHz Ref Adj.....	5-6, 5-8, 5-10, 5-24	Data.....	5-6, 5-7, 5-9, 5-17, 5-18, 5-20
ALC Mode	5-8, 5-23	Data Polarity	5-6, 5-9
CAL.....	5-8, 5-25	Direction	5-7, 5-17, 5-19
BER.....	5-6, 5-9	Ext I/Q Setup.....	5-8, 5-24
CH Start Freq	5-8, 5-22	Ext Trigger	5-7, 5-21
CH Start No.....	5-8, 5-22	Ext Trigger Setup.....	5-7, 5-21
CH Step Freq.....	5-8, 5-22	FBI Pattern	5-7, 5-19
CPICH.....	5-6	FEC	5-7, 5-18, 5-20, 5-21
CRC.....	5-7, 5-18, 5-20, 5-21	FREQ	5-9
Cal Corr ON/OFF.....	5-8, 5-25	General Setup.....	5-6, 5-11
Cal/Test	5-8, 5-25	Freq Input.....	5-8, 5-22
Bit Length	5-6, 5-9	Frequency & Level	5-6, 5-22
Clock & Timing Setup.....	5-6, 5-8, 5-10, 5-23	Frequency Setup.....	5-8, 5-22
Clock Edge.....	5-6, 5-9	I Gain	5-8, 5-25
Clock Out 1	5-6, 5-8, 5-10, 5-24	I/Q Direction	5-6, 5-8, 5-16, 5-24
Clock Out 2	5-6, 5-8, 5-10, 5-24	I/Q Phase Adj.....	5-8, 5-25
Count.....	5-7, 5-17, 5-19	LEVEL.....	5-9
DPCCH Gain Code	5-6, 5-15	MOD-TB In	5-6, 5-8, 5-10, 5-24
DPCCH Power Ratio	5-6, 5-15	Level Offset	5-8, 5-22
DPCCH Setup	5-7, 5-16, 5-19	Level Setup	5-8, 5-22
DPCCH Slot Format	5-6, 5-14	Link	5-6, 5-16
DPCH	5-6	Modulation.....	5-6, 5-10
DPCH Channel Config.....	5-6, 5-12	Modulation ON/OFF.....	5-6, 5-8, 5-9, 5-16, 5-23, 5-26
DPCH Channel. Code	5-6, 5-13	Offset Value	5-8, 5-22
DPDCH Channel Conf.....	5-6, 5-13	Other	5-6, 5-23
DPDCH Data.....	5-6, 5-13, 5-14	Output ON/OFF	5-6, 5-8, 5-10, 5-16, 5-23, 5-26
DPDCH Gain Code	5-6, 5-15		
DPDCH Power Ratio	5-6, 5-15		
DTCH/DCCH Setup	5-7, 5-17,		

Q Gain.....	5-8, 5-25
P-CCPCH.....	5-6
Parameter Setup.....	5-6, 5-9
Preset.....	5-8, 5-26
Quit.....	5-6, 5-10, 5-26
REPEAT.....	5-9
SINGLE.....	5-9
START.....	5-9
STD Setup.....	5-6, 5-15
STOP.....	5-9
Save.....	5-8, 5-25
Save Register List.....	5-8
Scrambling Code.....	5-6, 5-11, 5-13
Recall.....	5-8, 5-26
Recall Register List.....	5-8
Self Test.....	5-8, 5-25
Step Size.....	5-8, 5-22, 5-23
Rx Control [R3562].....	5-6
Synthe Ref In.....	5-6, 5-8, 5-10, 5-23
TFCL.....	5-7, 5-17, 5-19
TPC Insert.....	5-7, 5-16, 5-19
TPC Repeat Count.....	5-7, 5-17, 5-19
Unit.....	5-8, 5-22
Upper Limit.....	5-8, 5-22
Trig Polarity.....	5-7, 5-21
Trigger Delay.....	5-7, 5-21
[Channel Power Ratio].....	5-6, 5-13
[DCCH].....	5-7, 5-18, 5-20
[DTCH].....	5-7, 5-17, 5-20
[Gain Parameter].....	5-6, 5-15
[I/Q Input].....	5-8, 5-25
[I/Q Output].....	5-8, 5-25
[TPC Insert].....	5-7, 5-17, 5-19

5.2 Reference

5.2.2 Menu Map

A list of soft menus, which are under the ADVANCE key, used with the R3562 are shown below.

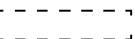
NOTE:  Represents a panel key.
 Represents a dialog box.
 Unless otherwise noted, the soft menus are shown.

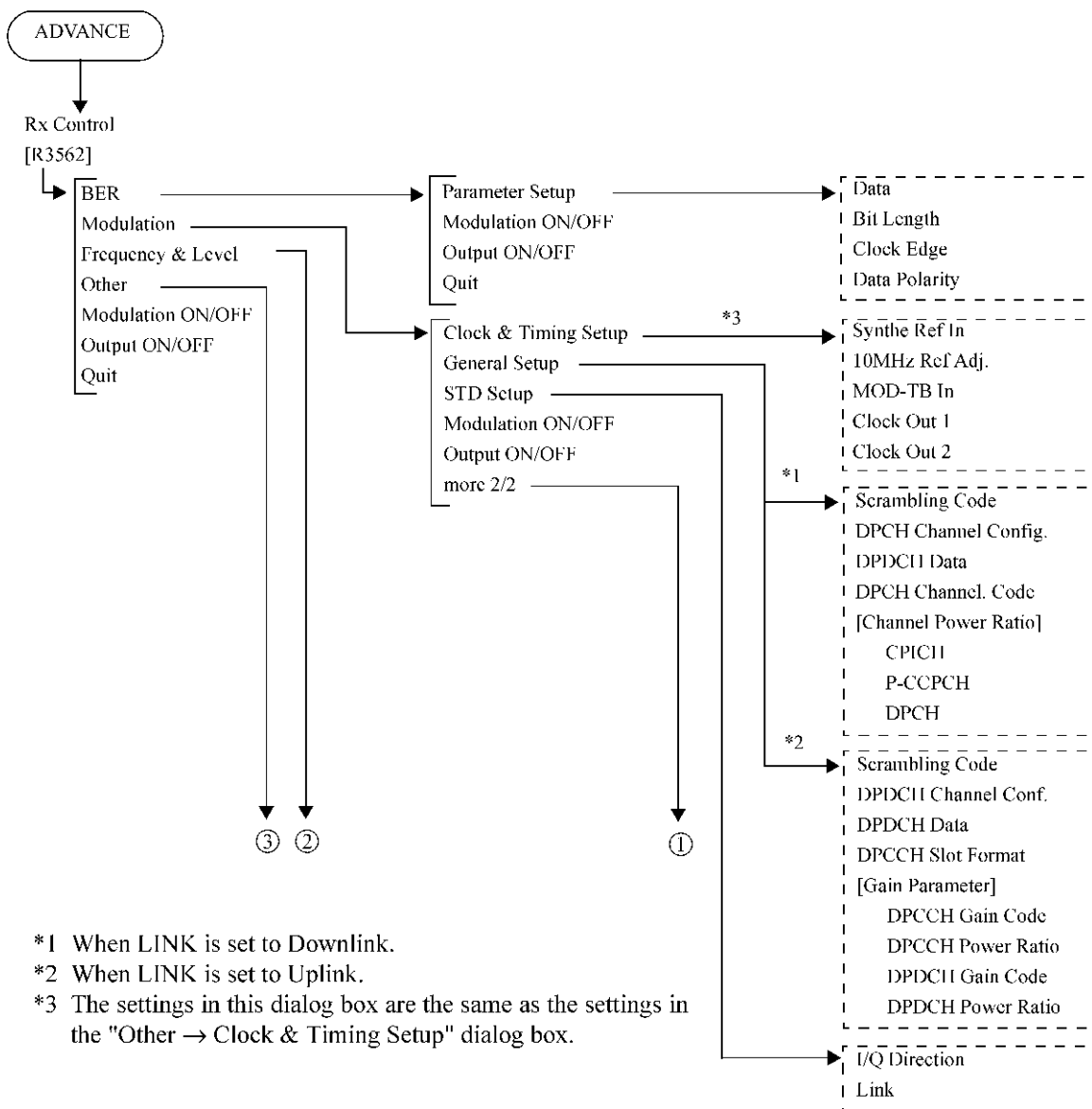

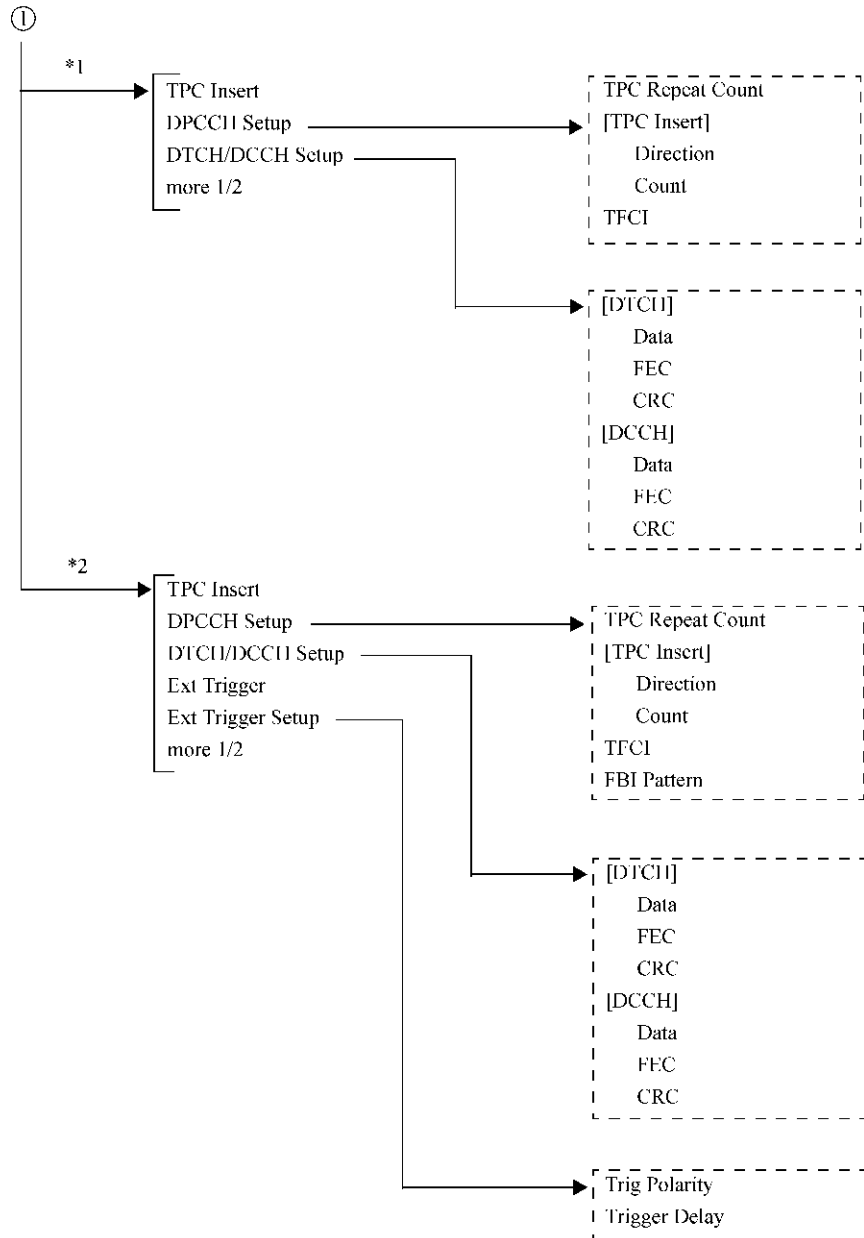

*1 When LINK is set to Downlink.

*2 When LINK is set to Uplink.

5.2 Reference

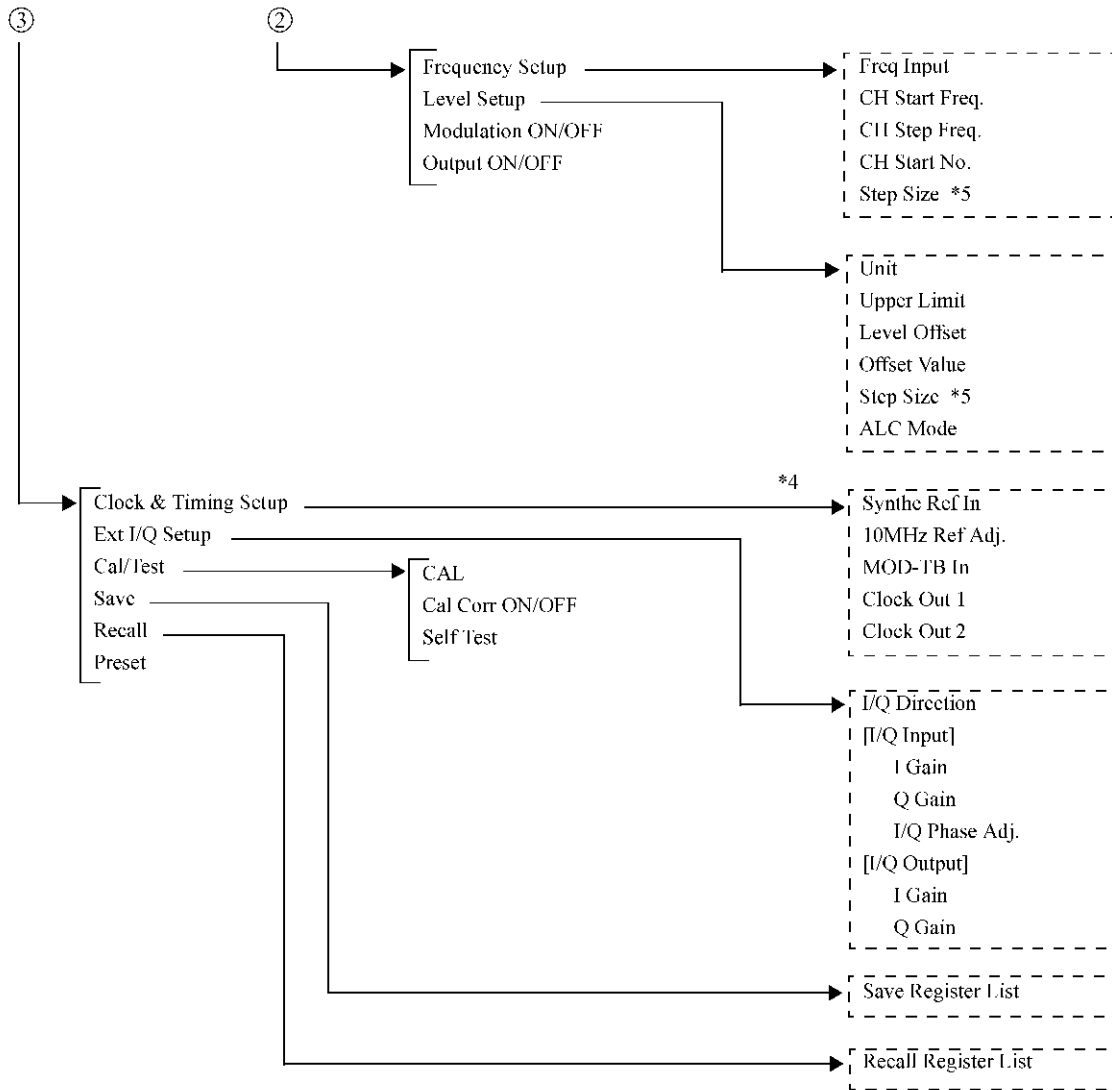

*4 The settings in this dialog box are the same as the settings in the "Modulation → Clock & Timing Setup dialog box."

*5 Sets the step size for the step keys(data knob) on the R3267 Series.

5.2.3 Functional Description

This section describes the front panel keys and the soft menus associated with them.

FREQ	A window prompting numeric values is displayed. Sets the output frequency. Use the up or down keys, the data knob and the numeric keys to enter data.
LEVEL	A window prompting numeric values is displayed. Used to set the output level. Use the up or down keys, the data knob and the numeric keys to enter data.
SINGLE	Makes one BER measurement.
REPEAT (START/STOP)	Makes repeated BER measurements, or stops the current BER measurement.
BER	Displays the BER Measurement Mode menu.
Parameter Setup	Displays the BER Parameter Setup dialog box.

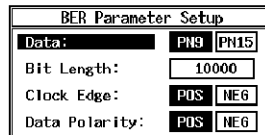

Figure 5-4 BER Parameter Setup Dialog Box

Data	Selects test data type. PN9: Selects PN9. PN15: Selects PN15.
Bit Length	Set BER measurement time with the bit length. The setting range of the bit length is 1000 to 10000000 bits.
Clock Polarity	Select from which edge you get data, the rising edge of the signal from BER clock terminal or the falling edge. POS: Rising NEG: Falling
Data Polarity	Select if you invert BER DATA terminal data or not. POS: Positive logic (not invert) NEG: Negative logic (invert)
Modulation ON/OFF	Turns the RF output modulation function on or off. ON: Modulates the RF output using transmission data.

5.2 Reference

- Output ON/OFF**
 - OFF: Does not modulate the RF output.
 - Turns the RF output on or off.
 - ON: Turns the RF signal on.
 - OFF: Turns the RF signal off.
- Quit**
 - Exits from BER Measurement Mode.
- Modulation**
 - Displays the modulation 1/2 menu.
- Clock & Timing Setup**
 - Displays the Clock/Timing Signal Parameter Setup dialog box.

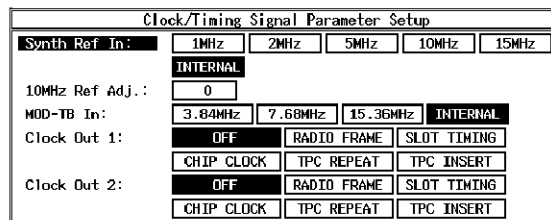

Figure 5-5 Clock/Timing Signal Parameter Setup Dialog Box

- Synthe Ref In**
 - Selects the reference signal from the synthesizer.
 - 1 MHz: Uses an external signal of 1 MHz.
 - 2 MHz: Uses an external signal of 2 MHz.
 - 5 MHz: Uses an external signal of 5 MHz.
 - 10 MHz: Uses an external signal of 10 MHz.
 - 15 MHz: Uses an external signal of 15 MHz.
 - INTERNAL: Uses the internal reference signal.
- 10MHz Ref Adj.**
 - Sets internal reference signal's frequency difference to be corrected.
- MOD-TB In**
 - Selects the reference signal used for the modulation.
 - 3.84 MHz: Uses an external signal of 3.84 MHz.
 - 7.68 MHz: Uses an external signal of 7.68 MHz.
 - 15.36 MHz: Uses an external signal of 15.36 MHz.
 - INTERNAL: Uses the internal reference signal.
- Clock Out 1/Clock Out 2**
 - Outputs the modulation timing signals to the CLOCK OUT1 and CLOCK OUT2 connectors.
 - OFF: Turns the output signal off.
 - RADIO FRAME:
 - Outputs the timing for the radio frame.

SLOT TIMING:

Outputs the slot timing.

CHIP CLOCK:

Outputs the CHIP clock.

TPC REPEAT:

Outputs the first slot timing used for the TPC command sequence during Repeat operation.

TPC INSERT:

Outputs the first slot timing used for the TPC command sequence during the Insert operation.

General Setup

Displays the General Parameter setup dialog box.

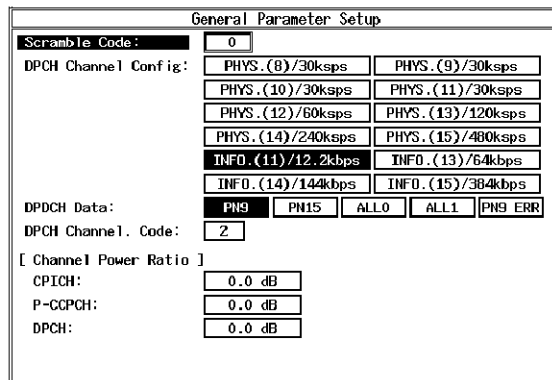

Figure 5-6 General Parameter Setup Dialog box (For the Downlink)

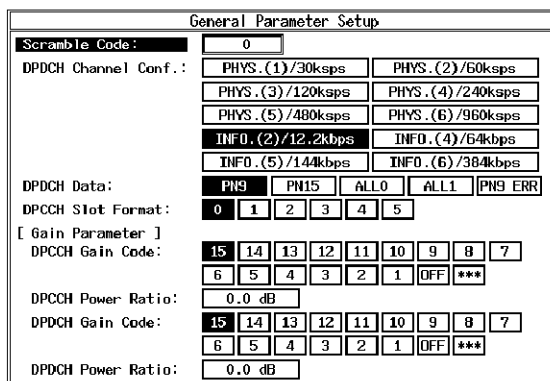

Figure 5-7 General Parameter Setup Dialog box (For the Uplink)

<When set to Downlink>

Scrambling Code Sets the scrambling code number.

DPCH Channel Config.

Select the channel configuration from the following list.

PHYS.(8)/30ksps:

Assigns Physical Data Mode with a slot format number of 8 and a channel symbol rate of 30 [ksps].

PHYS.(9)/30ksps:

Assigns Physical Data Mode with a slot format number of 9 and a channel symbol rate of 30 [ksps].

PHYS.(10)/30ksps:

Assigns Physical Data Mode with a slot format number of 10 and a channel symbol rate of 30 [ksps].

PHYS.(11)/30ksps:

Assigns Physical Data Mode with a slot format number of 11 and a channel symbol rate of 30 [ksps].

PHYS.(12)/60ksps:

Assigns Physical Data Mode with a slot format number of 12 and a channel symbol rate of 60 [ksps].

PHYS.(13)/120ksps:

Assigns Physical Data Mode with a slot format number of 13 and a channel symbol rate of 120 [ksps].

PHYS.(14)/240ksps:

Assigns Physical Data Mode with a slot format number of 14 and a channel symbol rate of 240 [ksps].

PHYS.(15)/480ksps:

Assigns Physical Data Mode with a slot format number of 15 and a channel symbol rate of 480 [ksps].

INFO.(11)/12.2kbps:

Assigns Information Data Mode with a slot format number of 11, an information bit rate of 12.2 [kbps] and a channel symbol rate of 30 [ksps].

INFO.(13)/64kbps:

Assigns Information Data Mode with a slot format number of 13, an information bit rate of 64 [kbps] and a channel symbol rate of 120 [ksps].

INFO.(14)/144kbps:

Assigns Information Data Mode with a slot format number of 14, an information bit rate of 144 [kbps] and a channel symbol rate of 240 [ksps].

INFO.(15)/384kbps:

Assigns Information Data Mode with a slot format

number of 15, an information bit rate of 384 [kbps] and a channel symbol rate of 480 [ksps].

DPDCH Data Selects the data to be input to the DPDCH when DPCH Channel Config is set to Physical Data Mode.

PN9: Selects PN9.

PN15: Selects PN15.

ALL0: Selects all zero data.

ALL1: Selects all one data.

PN9 ERR: Selects PN9 with an error of 1%.

DPCH Channel. Code

Sets the channelization code number.

[Channel Power Ratio]

Sets the power ratios for the following physical channels.

CPICH: Sets a power ratio for CPICH.

P-CCPCH: Sets a power ratio for P-CCPCH and SCH.

DPCH: Sets a power ratio for DPCH.

NOTE: *When a channel power ratio of -99.9 dB is specified, the specified channel power is turned off.*

<When set to Uplink>

Scrambling Code Sets the scrambling code number.

DPDCH Channel Conf.

Select the channel configuration from the following list.

PHYS.(1)/30ksps:

Assigns Physical Data Mode with a slot format number of 1 and a channel symbol rate of 30 [ksps].

PHYS.(2)/60ksps:

Assigns Physical Data Mode with a slot format number of 2 and a channel symbol rate of 60 [ksps].

PHYS.(3)/120ksps:

Assigns Physical Data Mode with a slot format number of 3 and a channel symbol rate of 120 [ksps].

PHYS.(4)/240ksps:

Assigns Physical Data Mode with a slot format number of 4 and a channel symbol rate of 240 [ksps].

5.2 Reference

- PHYS.(5)/480ksps:
Assigns Physical Data Mode with a slot format number of 5 and a channel symbol rate of 480 [ksps].
- PHYS.(6)/960ksps:
Assigns Physical Data Mode with a slot format number of 6 and a channel symbol rate of 960 [ksps].
- INFO.(2)/12.2kbps:
Assigns Information Data Mode with a slot format number of 2, an information bit rate of 12.2 [kbps] and a channel symbol rate of 60 [ksps].
- INFO.(4)/64kbps:
Assigns Information Data Mode with a slot format number of 4, an information bit rate of 64 [kbps] and a channel symbol rate of 240 [ksps].
- INFO.(5)/144kbps:
Assigns Information Data Mode with a slot format number of 5, an information bit rate of 144 [kbps] and a channel symbol rate of 480 [ksps].
- INFO.(6)/384kbps:
Assigns Information Data Mode with a slot format number of 6, an information bit rate of 384 [kbps] and a channel symbol rate of 960 [ksps].

DPDCH Data Selects the data to be input to the DPDCH when DPDCH Channel Config is set to Physical Data Mode.

- PN9: Selects PN9.
- PN15: Selects PN15.
- ALL0: Selects all zero data.
- ALL1: Selects all one data.
- PN9 ERR: Selects PN9 code with an error of 1%.

DPCCH Slot Format

Selects a slot format from the following list.

- 0: Uses the bit configuration for the slot format number 0.
- 1: Uses the bit configuration for the slot format number 1.
- 2: Uses the bit configuration for the slot format number 2.
- 3: Uses the bit configuration for the slot format number 3.
- 4: Uses the bit configuration for the slot format number 4.

5: Uses the bit configuration for the slot format number 5.

[Gain Parameter] Sets the gain (power) ratio for a DPCCH to a DPDCH. There are four possible combinations.

DPCCH Gain Code

Sets the ratio for DPCCH gain to β_c , using the gain parameter code if DPDCH gain to β_d is 1.

- 1 thru 15: The gain ratio complies with the 3GPP standard.
- OFF: Turns the DPCCH power off.
- ***: Displays the situation under which an incorrect value for the gain power code was used to set a DPCCH power ratio.

DPCCH Power Ratio

Sets the ratio for the DPCCH power to P_c [dB] if the ratio of DPDCH to P_d is 0 [dB].

NOTE: The DPDCH power is turned off if -99.9 dB is specified.

DPDCH Gain Code

Sets the ratio for DPDCH gain to β_d , using the gain parameter code if DPCCH gain to β_c is 1.

- 1 thru 15: The gain ratio complies with the 3GPP standard.
- OFF: Turns the DPDCH power off.
- ***: Displays the situation under which an incorrect value for the gain power code was used to set a DPDCH power ratio.

DPDCH Power Ratio

Sets the ratio for the DPDCH power to P_d [dB] if the ratio of DPCCH to P_c is 0 [dB].

NOTE: The DPCCH power is turned off if -99.9 dB is specified.

STD Setup

Displays the STD Parameter setup dialog box.

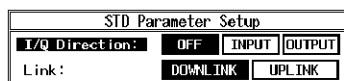

Figure 5-8 STD Parameter Setup Dialog box

5.2 Reference

I/Q Direction Exchanges the external IQ terminals between the input and output and selects the IQ signal paths to the IQ modulator.

OFF: Turns off the IQ output, and inputs the internal baseband signal to the IQ modulator.

INPUT: Inputs the IQ signal from the outside to the IQ modulator.

OUTPUT: Turns on the IQ output, and inputs the internal baseband signal to the IQ modulator.

NOTE: *The level and modulation accuracy of the RF output cannot be guaranteed while in the OUTPUT mode.*

Link Selects the link direction.

DOWNLINK: Outputs the Downlink signal.

UPLINK: Outputs the Uplink signal.

Modulation ON/OFF Turns the RF output modulation function on or off.

ON: Modulates the RF output using transmission data.

OFF: Does not modulate the RF output.

Output ON/OFF Turns the RF output on or off.

ON: Turns the RF signal on.

OFF: Turns the RF signal off.

more 2/2 Displays the modulation 2/2 menu.

<When set to Downlink>

TPC Insert The TPC command is inserted during Repeat operation. The direction and slot length of the TPC command you want to insert can be specified in the TPC Insert item in the DPCCH Parameter dialog box.

DPCCH Setup Displays the DPCCH Parameter Setup dialog box.

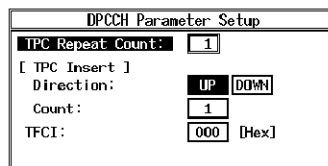

Figure 5-9 DPCCH Parameter Setup Dialog box (For the Downlink)

TPC Repeat Count

Sets the TPC slot length for the Repeat operation.

[TPC Insert]

Inserts TPC commands of 1 or 0 into consecutive slots as specified by the TPC insertion slot length during the Repeat operation.

Direction

Selects the direction (Up or Down) during the Insert operation.

UP: Inserts TPC commands of 1 into consecutive slots.

DOWN: Inserts TPC commands of 0 into consecutive slots.

Count

Sets the TPC insertion slot length used during Insert operation.

TFCI

Sets a TFCI consisting of one frame in hexadecimal. The TFCI is specified using 10 TFCI bits, which are input to the TFCI coder.

Input value Operation

A: Shift→0

B: Shift→1

C: Shift→2

D: Shift→3

E: Shift→4

F: Shift→5

DTCH/DCCH Setup

Displays the DTCH/DCCH Parameter setup dialog box.

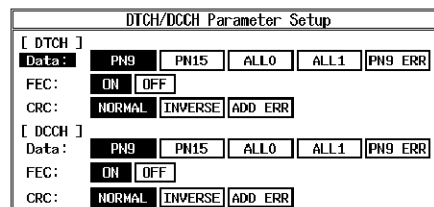

**Figure 5-10 DTCH/DCCH Parameter Setup Dialog box
(For the Downlink)**

[DTCH]

The DTCH value set when the data mode for the channel configuration settings is set to Information Data Mode is valid.

Data

Selects the data used for Information data.

PN9: Selects PN9.

PN15: Selects PN15.

ALL0: Selects all zero data.

ALL1: Selects all one data.

PN9 ERR: Selects PN9 with an error of 1%.

5.2 Reference

<i>FEC</i>	<p>Sets whether or not FEC (Convolutional or Turbo Coding) processing is performed.</p> <p>ON: FEC processing is performed.</p> <p>OFF: FEC processing is not performed.</p>
<i>CRC</i>	<p>Sets the mode used to generate CRC data which is based on the calculated CRC value.</p> <p>NORMAL: The calculated CRC value is used as CRC data (correct CRC data is output).</p> <p>INVERSE: The value obtained by logically inverting the CRC is used as CRC data (incorrect CRC data is output).</p> <p>ADD ERR: A block containing an error of 1% is generated using the NORMAL operation linked with the INVERSE operation.</p>
<i>[DCCH]</i>	<p>The DCCH value set when the data mode for the channel configuration settings is set to Information Data Mode is valid.</p>
<i>Data</i>	<p>Selects the data used for Information data.</p> <p>PN9: Selects PN9.</p> <p>PN15: Selects PN15.</p> <p>ALL0: Selects all zero data.</p> <p>ALL1: Selects all one data.</p> <p>PN9 ERR: Selects PN9 with an error of 1%.</p>
<i>FEC</i>	<p>Sets whether or not FEC (Convolutional or Turbo Coding) processing is performed.</p> <p>ON: FEC processing is performed.</p> <p>OFF: FEC processing is not performed.</p>
<i>CRC</i>	<p>Sets the mode used to generate CRC data which is based on the calculated CRC value.</p> <p>NORMAL: The calculated CRC value is used as CRC data (correct CRC data is output).</p> <p>INVERSE: The value obtained by logically inverting the CRC is used as CRC data (incorrect CRC data is output).</p> <p>ADD ERR: A block containing an error of 1% is generated using the NORMAL operation linked with the INVERSE operation.</p>
<i>more 1/2</i>	<p>Displays the modulation 1/2 menu.</p>

<When set to Uplink>

TPC Insert

The TPC command is inserted during Repeat operation. The direction and slot length of the TPC command you want to insert can be specified in the TPC Insert item in the DPCCH Parameter dialog box.

DPCCH Setup

Displays the DPCCH Parameter Setup dialog box.

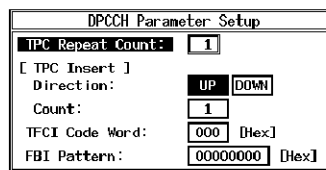

**Figure 5-11 DPCCH Parameter Setup Dialog box
(For the Uplink)**

TPC Repeat Count

Sets the TPC slot length for the Repeat operation.

[TPC Insert]

Inserts TPC commands of 1 or 0 into consecutive slots as specified by the TPC insertion slot length during the Repeat operation.

Direction

Selects the direction (Up or Down) during the Insert operation.

UP: Inserts TPC commands of 1 into consecutive slots.

DOWN: Inserts TPC commands of 0 into consecutive slots.

Count

Sets the TPC insertion slot length used during Insert operation.

TFCI

Sets a TFCI consisting of one frame in hexadecimal. The TFCI is specified using 10 TFCI bits, which are input to the TFCI coder.

Input value	Operation
A:	Shift→ 0
B:	Shift→ 1
C:	Shift→ 2
D:	Shift→ 3
E:	Shift→ 4
F:	Shift→ 5

FBI Pattern

Sets a FBI bit pattern consisting of one frame in hexadecimal. The number of FBI bits per slot is determined by the DPCCH channel configuration settings: if the number is not 0, the value in the FBI bit pattern setting is valid.

DTCH/DCCH Setup

Displays the DTCH/DCCH Parameter setup dialog box.

5.2 Reference

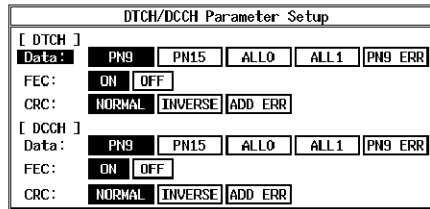

**Figure 5-12 DTCH/DCCH Parameter Setup Dialog box
(For the Downlink)**

[DTCH]

The DTCH value set when the data mode for the channel configuration settings is set to Information Data Mode is valid.

Data

Selects the data used for Information data.

- PN9: Selects PN9.
- PN15: Selects PN15.
- ALL0: Selects all zero data.
- ALL1: Selects all one data.
- PN9 ERR: Selects PN9 with an error of 1%.

FEC

Sets whether or not FEC (Convolutional or Turbo Coding) processing is performed.

- ON: FEC processing is performed.
- OFF: FEC processing is not performed.

CRC

Sets the mode used to generate CRC data which is based on the calculated CRC value.

- NORMAL: The calculated CRC value is used as CRC data (correct CRC data is output).
- INVERSE: The value obtained by logically inverting the CRC is used as CRC data (incorrect CRC data is output).
- ADD ERR: A block containing an error of 1% is generated using the NORMAL operation linked with the INVERSE operation.

[DCCH]

The DCCH value set when the data mode for the channel configuration settings is set to Information Data Mode is valid.

Data

Selects the data used for Information data.

- PN9: Selects PN9.
- PN15: Selects PN15.
- ALL0: Selects all zero data.
- ALL1: Selects all one data.

PN9 ERR: Selects PN9 with an error of 1%.

FEC Sets whether or not FEC (Convolutional or Turbo Coding) processing is performed.

ON: FEC processing is performed.

OFF: FEC processing is not performed.

CRC Sets the mode used to generate CRC data which is based on the calculated CRC value.

NORMAL: The calculated CRC value is used as CRC data (correct CRC data is output).

INVERSE: The value obtained by logically inverting the CRC is used as CRC data (incorrect CRC data is output).

ADD ERR: A block containing an error of 1% is generated using the NORMAL operation linked with the INVERSE operation.

Ext Trigger

Synchronizes the baseband block (of this instrument) to the EXT TRIG IN signal. When this command is entered, the baseband block of this instrument is ready to receive the trigger signal from the EXT TRIG IN terminal.

NOTE: This function is enabled only when LINK is set to Uplink (UE→BS).

Ext Trigger Setup

Displays the Ext Trigger Parameter setup dialog box.

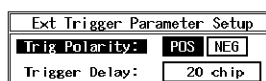

Figure 5-13 Ext Trigger Parameter Setup Dialog box

Trig Polarity

Sets which edge of the signal input to the EXT TRIG IN terminal is used to synchronize the baseband block in this instrument.

POS: The rising edge is used to synchronize the baseband block.

NEG: The falling edge is used to synchronize the baseband block.

Trigger Delay

Sets the delay time (chips) from when the trigger signal is input to when the base band block is synchronized.

A time delay of "Setting value + 1024 (a UL-DL Timing offset which is compliant with the 3GPP standard)" is obtained.

more 1/2

Displays the modulation 1/2 menu.

5.2 Reference

Frequency & Level

Displays the Frequency & Level menu.

Frequency Setup

Displays the Frequency Parameter Setup dialog box.

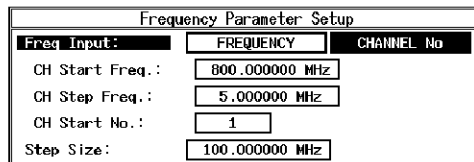

Figure 5-14 Frequency Parameter Setup Dialog Box

Freq Input

Selects the frequency entry mode.

FREQUENCY:

Directly enters a frequency value.

CHANNEL No:

Enters a channel number.

CH Start Freq.

Sets the channel start frequency.

CH Step Freq.

Sets the channel spacing.

CH Start No.

Sets the channel start number.

Step Size

Sets the step value of the step keys and data knob.

Level Setup

Displays the Level Parameter Setup dialog box.

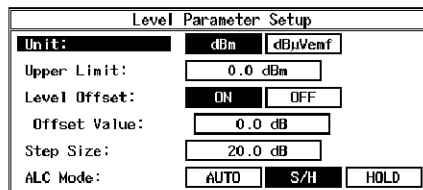

Figure 5-15 Level Parameter Setup Dialog Box

Unit

Selects the unit to display or enter the data.

dBm: Sets a level-related unit to dBm.

dBµVemf: Sets a level-related unit to dBµVemf.

Upper Limit

Sets the upper limit.

Level Offset

Toggles the level offset function on or off.

ON: Turns the level offset function on.

OFF: Turns the level offset function off.

Offset Value

Sets the level offset value.

Step Size	Sets the step value of the step keys.
ALC Mode	<p>Selects the ALC operating mode. Automatically selects the optimum operating mode depending on the R3562 settings. (For details, refer to the R3562 Operation manual.)</p> <p>AUTO: Normal ALC</p> <p>S/H: Sample and hold using the reference modulation pattern.</p> <p>HOLD: ALC voltage hold when the reference modulation pattern is used.</p>

NOTE: When not set to the optimum operation mode, the output from the RF OUT terminal may deviate from the target value.

Modulation ON/OFF

Turns the RF output modulation function on or off.

ON: Modulates the RF output using transmission data.

OFF: Does not modulate the RF output.

Output ON/OFF

Turns the RF output on or off.

ON: Turns the RF signal on.

OFF: Turns the RF signal off.

Other

Displays the Other menu.

Clock & Timing Setup

Displays the Clock/Timing Signal Parameter Setup dialog box.

Clock/Timing Signal Parameter Setup					
Synth Ref In:	1MHz	2MHz	5MHz	10MHz	15MHz
	INTERNAL				
10MHz Ref Adj.:	0				
MOD-TB In:	3.84MHz	7.68MHz	15.36MHz	INTERNAL	
Clock Out 1:	OFF	RADIO FRAME	SLOT TIMING		
	CHIP CLOCK	TPC REPEAT	TPC INSERT		
Clock Out 2:	OFF	RADIO FRAME	SLOT TIMING		
	CHIP CLOCK	TPC REPEAT	TPC INSERT		

Figure 5-16 Clock/Timing Signal Parameter Setup Dialog Box

Synthe Ref In

Selects the reference signal from the synthesizer.

1 MHz: Uses an external signal of 1 MHz.

2 MHz: Uses an external signal of 2 MHz.

5 MHz: Uses an external signal of 5 MHz.

10 MHz: Uses an external signal of 10 MHz.

5.2 Reference

15 MHz: Uses an external signal of 15 MHz.

INTERNAL: Uses the internal reference signal.

10MHz Ref Adj. Sets internal reference signal's frequency difference to be corrected.

MOD-TB In Selects the reference signal used for the modulation.

3.84 MHz: Uses an external signal of 3.84 MHz.

7.68 MHz: Uses an external signal of 7.68 MHz.

15.36 MHz: Uses an external signal of 15.36 MHz.

INTERNAL: Uses the internal reference signal.

Clock Out 1/Clock Out 2

Outputs the modulation timing signals to the CLOCK OUT1 and CLOCK OUT2 connectors.

OFF: Turns the output signal off.

RADIO FRAME: Outputs the timing for the radio frame.

SLOT TIMING: Outputs the slot timing.

CHIP CLOCK: Outputs the CHIP clock.

TPC REPEAT: Outputs the first slot timing used for the TPC command sequence during Repeat operation.

TPC INSERT: Outputs the first slot timing used for the TPC command sequence during the Insert operation.

Ext I/Q Setup Displays the External I/Q Parameter Setup dialog box.

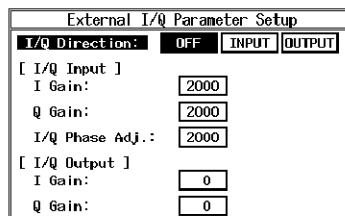

Figure 5-17 External I/Q Parameter Setup Dialog Box

I/Q Direction Exchanges the external IQ terminals between the input and output and selects the IQ signal paths to the IQ modulator.

OFF: Turns off the IQ output, and inputs the internal baseband signal to the IQ modulator.

INPUT: Inputs the IQ signal from the outside to the IQ modulator.
OUTPUT: Turns on the IQ output, and inputs the internal baseband signal to the IQ modulator.

NOTE: *The level and modulation accuracy of the RF output cannot be guaranteed while in the OUTPUT mode.*

[I/Q Input] Sets the parameter if I/Q Direction is set to Input.

I Gain Sets the gain of the amplifier that inputs the I signal.

Q Gain Sets the gain of the amplifier that inputs the Q signal.

I/Q Phase Adj.
 Sets the phase difference to be corrected

[I/Q Output] Sets the parameter if I/Q Direction is set to Output.

I Gain Sets the gain of the amplifier that outputs the I signal.

Q Gain Sets the gain of the amplifier that outputs the Q signal.

Cal/Test Displays the Cal/Test menu.

CAL Performs a calibration. When the calibration is completed, the correction value obtained from the calibration can be used.

Cal Corr ON/OFF
 Selects the calibration correction mode on or off.

ON: Makes the correction value obtained from the calibration be used.

OFF: Does not perform the correction.

Self Test The self-test is run.

Save Displays the Save Register List dialog box. Save is performed when the **ENTER** is pressed after the register has been selected.

Save Register List						
No.	I/Q Dir.	Link	Frequency	Level	Output	
1:	INPUT	UPLINK	2110.000000MHz	-80.0dBm	ON	
2:	OUTPUT	DOWNLINK	1000.000000MHz	-80.0dBm	ON	
3:	empty					

Figure 5-18 Save Register List Dialog Box

5.2 Reference

Recall

Displays the Recall Register List dialog box. Recall is performed when the ENTER is pressed after the register has been selected.

Recall Register List					
No.	I/Q Dir.	Link	Frequency	Level	Output
1:	INPUT	UPLINK	2110.000000MHz	-80.0dBm	ON
2:	OUTPUT	DOWNLINK	1000.000000MHz	-80.0dBm	ON
3:	empty				

Figure 5-19 Recall Register List Dialog Box

Preset

Initializes the settings.

Modulation ON/OFF

Turns the RF output modulation function on or off.

ON: Modulates the RF output using transmission data.

OFF: Does not modulate the RF output.

Output ON/OFF

Turns the RF output on or off.

ON: Turns the RF signal on.

OFF: Turns the RF signal off.

Quit

Exits from the Rx Control option.

5.3 Measurement Example

This example shows the BER measurement of channel used in the Downlink.

Measurement conditions: The items to be measured are shown below. Set the measurement conditions to be suitable for the targeted measurement.

Output signal

Frequency:	2110 MHz
Output level:	-80 dBm
Link:	DOWNLINK
DPCH channel configuration:	Information mode Slot format number=11, Information bit rate=12.2kbps
Scrambling Code:	0
DPCH Channelization Code:	2
DTCH data:	PN9

BER counter

Measurement data pattern:	PN9
Measurement data length:	10000 bits
Input clock polarity:	NEG (trailing edge)
Input data polarity:	POS (noninverting)

Setup

1. Connect the instrument as shown below.

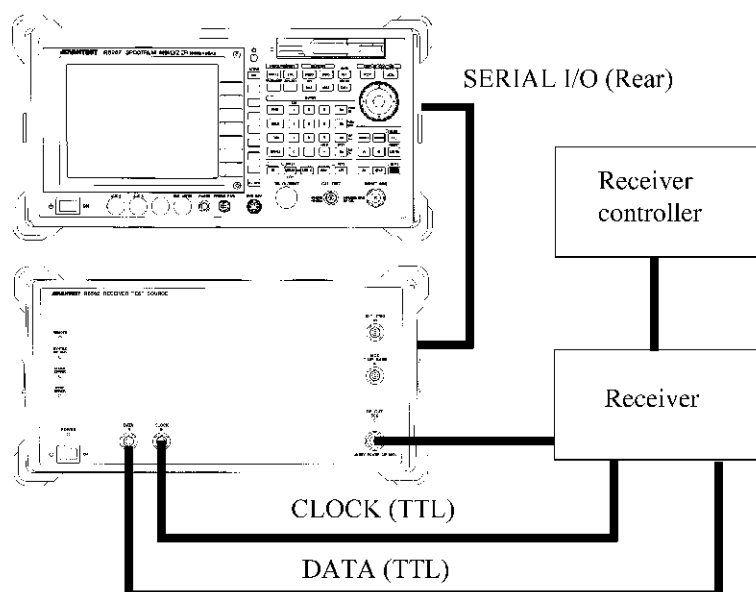

Figure 5-20 Connecting the DUT

5.3 Measurement Example

Setting up the unit under test

2. The measurement conditions are set according to the specifications of the unit under test.

Initialization

3. Press **ADVANCE**, *Rx Control*[R3562], *Other* and *Preset*.

Setting the output signal

4. Press **FREQ**, **2**, **1**, **1**, **0** and **MHz**.
5. Press **Level**, **-**, **8**, **0** and **GHz(dBm)**.
6. Press *Modulation* and *STD Setup*.
The STD Parameter Setup dialog box is displayed.

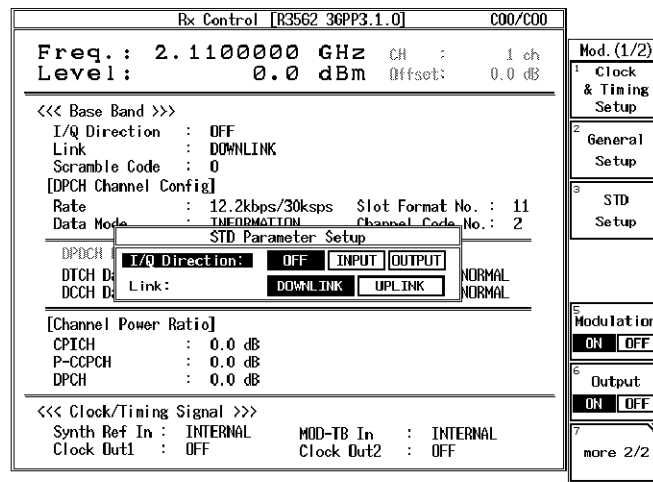

Figure 5-21 STD Parameter Setup Dialog Box

7. Set the following items.
I/Q direction:OFF
Link:Downlink
8. Press *General Setup*.
The General Parameter Setup dialog box is displayed.

Rx Control [R3562 36PP3.1.0] C00/C00			
Freq.:	2.1100000 GHz	CH :	1 ch
Level:	0.0 dBm	Offset:	0.0 dB
General Parameter Setup			
Scramble Code:	0		
DPCH Channel Config:	PHYS.(8)/30ksp	PHYS.(9)/30ksp	
	PHYS.(10)/30ksp	PHYS.(11)/30ksp	
	PHYS.(12)/60ksp	PHYS.(13)/120ksp	
	PHYS.(14)/240ksp	PHYS.(15)/480ksp	
	INFO.(11)/12.2ksp	INFO.(13)/64ksp	
	INFO.(14)/144ksp	INFO.(15)/384ksp	
DPDCH Data:	PN9	PN15	ALLO ALL1 PN9 ERR
DPCH Channel. Code:	2		
[Channel Power Ratio]			
CPICH:	0.0 dB		
P-CCPCH:	0.0 dB		
DPCH:	0.0 dB		
<div style="float: right;"> Mod. (1/2) 1 Clock & Timing Setup 2 General Setup 3 STD Setup 4 5 Modulation ON OFF 6 Output ON OFF 7 more 2/2 </div>			

Figure 5-22 General Parameter Setup Dialog Box

9. Set the following items.

Scrambling Code:0

DPCH Channel Config:

INFO.(11)/12.2ksp

DPDCH DATA:PN9

DPCH Channel. Code:

2

[Channel Power Ratio]

CPICH: 0dB

P-CCPCH: 0dB

DPCH: 0dB

10. Press *more 2/2* and *DTCH/DCCH Setup*.
The DTCH/DCCH Parameter Setup dialog box is displayed.

5.3 Measurement Example

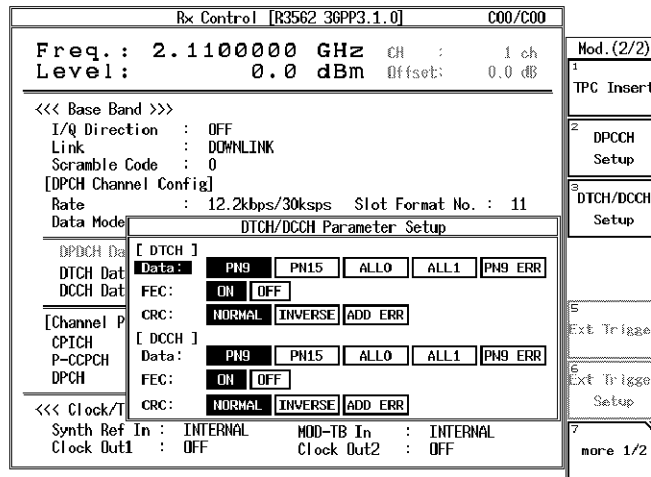

Figure 5-23 DTCH/DCCH Parameter Setup Dialog Box

- Set the following items for DTCH and DCCH.

Data:PN9
 FEC:ON
 CRC:NORMAL

- Press **Return**.

Setting the BER counter

- Press **BER** and **Parameter Setup**.
 The BER Parameter Setup dialog box is displayed.

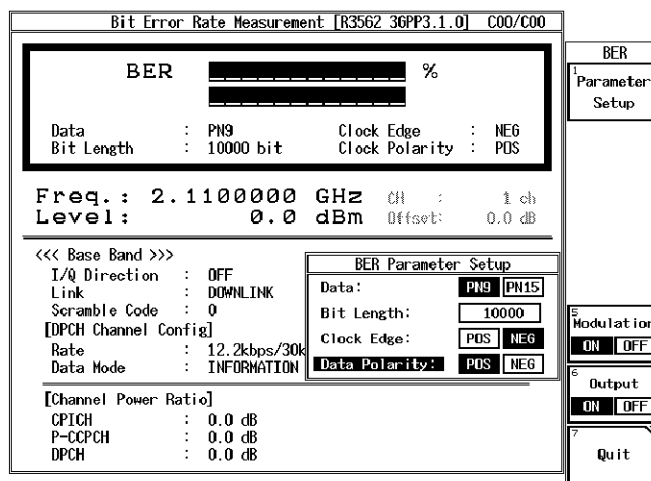

Figure 5-24 BER Parameter Setup Dialog Box

14. Set the following items.

Data:PN9

Bit Length:10000

Clock Edge:NEG

Data Polarity:POS

Starting the measurement

15. Press **REPEAT**.
The bit error rate is displayed.

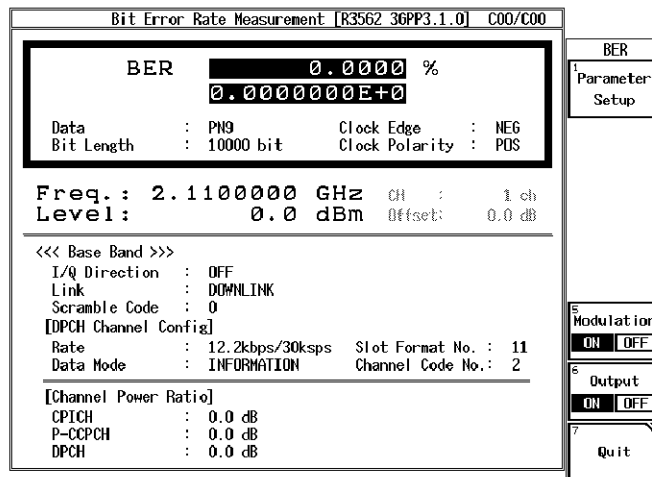

Figure 5-25 Measurement Result on the Bit Error Rate

6 HOW TO OPERATE THE R3562 OPT65

This chapter describes all key functions of the R3562 OPT65 cdma2000 option.

6.1 Outline

The operation menu of R3562 is placed under the **ADVANCE**.

Press **ADVANCE** and **Rx Control [R3562]**, R3267 Series becomes R3562 control mode and displays the screen shown in Figure 6-2 to set and measure R3562.

In this mode, operation with only soft-key or dialog box becomes effective except **FREQ** and **LEVEL**. The operation with **SPAN** and so on which can be used in ordinary operation mode cannot be performed. In order to return to the ordinary operation mode, press **POWER**, **UTIL**, **TRANSIENT** or **Quit**.

[Setting up the communication system]

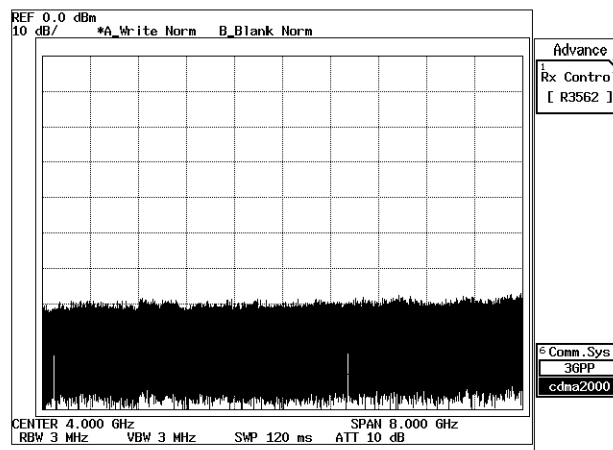

Figure 6-1 Initial Screen

To control the OPT65 (cdma2000) of R3562 using this option, the R3562 communication system must be set to the cdma2000 mode. When the Comm.sys key on the Initial screen is set to 3GPP (highlighted) (Figure 6-1), a mode is not set correctly.

Use the procedure below to change the communication system:

1. Press the Comm.sys key to set cdma2000 (highlighted).
2. Turn the R3562 power switch off, and then on again.

NOTE: Always perform steps 1 and 2 to change the communication system (performing step 1 only does not complete the operation).

6.1 Outline

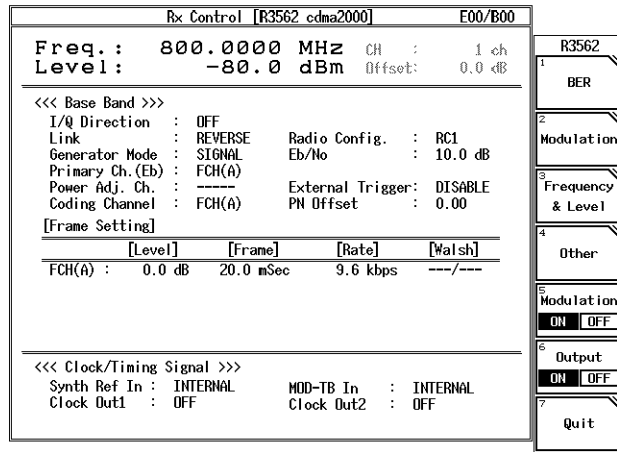

Figure 6-2 R3562 Control Main Screen (cdma2000)

6.2 Reference

This chapter describes the functions of all panel and soft keys.

- Menu Index: Use this index as a key index to Chapter 6.
- Menu Map: Shows a list of hierarchical menus on a panel key basis.
- Functional Description: Explains the functions of the panel and soft keys.

The panel keys are arranged in alphabetical order.

6.2.1 Menu Index

This menu index is used to easily find the keys described in Chapter 6.

<u>Operation Key</u>	<u>Pages</u>	<u>Operation Key</u>	<u>Pages</u>
10MHz Ref Adj.....	6-6, 6-10, 6-12, 6-43	Burst.....	6-6, 6-14
ALC Mode	6-10, 6-42	DATA	6-31, 6-33, 6-34, 6-35, 6-36, 6-37, 6-38, 6-39, 6-40
AWCN	6-44	DCCH Setup	6-9, 6-32
AWGN	6-10	EXT Trigger.....	6-14, 6-15
AWGN Cal Corr	6-44	Data	6-6, 6-9, 6-11
AWGN Cal Corr ON/OFF	6-10	Data Polarity	6-6, 6-11
Add. Bit Error	6-9, 6-32, 6-33, 6-34, 6-35, 6-36, 6-37, 6-38, 6-39, 6-40	Eb/No	6-6, 6-7, 6-15, 6-16, 6-19, 6-22
BER.....	6-6, 6-11	Entry Mode	6-9, 6-32
CH Start Freq.	6-10, 6-41	Error Ratio	6-9, 6-32, 6-33, 6-34, 6-35, 6-36, 6-37, 6-38, 6-39, 6-40
CH Start No.....	6-10, 6-41	Equalizing	6-19, 6-21
CH Step Freq.....	6-10, 6-41	Equalizing Filter.....	6-7
CRC.....	6-9, 6-31, 6-33, 6-34, 6-35, 6-36, 6-37, 6-38, 6-39, 6-40	Ext I/Q Setup.....	6-10, 6-43
Cal/Test	6-10, 6-44	External Trigger	6-6
Bit Length	6-6, 6-11	FCH(TRCH A) Setup	6-9, 6-31, 6-36
Clock & Timing Setup.....	6-6, 6-10, 6-12, 6-42	FCH(TRCH B) Setup.....	6-9, 6-34, 6-36, 6-39
Clock Edge.....	6-6, 6-11	FCH(TRCH C) Setup.....	6-9, 6-37
Block Interleaver.....	6-9, 6-32, 6-33, 6-34, 6-35, 6-36, 6-37, 6-38, 6-39, 6-40	FEC	6-25, 6-27, 6-28, 6-30
Clock Out 1	6-6, 6-10, 6-13, 6-43	FREQ	6-11
Clock Out 2	6-6, 6-10, 6-13, 6-43	Gating.....	6-9, 6-32
Coding Channel.....	6-8, 6-24, 6-26, 6-27,	Gating Rate	6-9, 6-32
		General Setup.....	6-6, 6-13, 6-15, 6-18,

6.2 Reference

Generator Mode	6-6, 6-7, 6-14, 6-16, 6-19, 6-21	SCH1(TRCH C) Setup.....	6-9
Frame	6-25, 6-26, 6-28, 6-30	SCH2(TRCH A) Setup	6-9, 6-33
Frame Setup	6-24, 6-25, 6-27, 6-28	REPEAT	6-11
Freq Input.....	6-10, 6-41	SINGLE	6-11
Frequency & Level.....	6-6, 6-40	START.....	6-11
Frequency Setup.....	6-10, 6-40	STD Setup.....	6-6, 6-24
I Gain.....	6-10, 6-44	STOP.....	6-11
I/Q Direction	6-7, 6-10, 6-24, 6-44	Radio Configuration.....	6-7, 6-24
I/Q Phase Adj.....	6-10, 6-44	Rate	6-25, 6-26, 6-28, 6-30
LEVEL.....	6-11	Save.....	6-10, 6-45
MOD-TB In.....	6-6, 6-10, 6-12, 6-43	Save Register List	6-10
Level Offset.....	6-10, 6-41	Recall	6-10, 6-45
Level Setup	6-10, 6-41	Recall Register List.....	6-10
Link	6-7, 6-24	Self Test	6-10, 6-45
Modulation	6-6, 6-12	Rep. Pattern.....	6-31, 6-33, 6-34, 6-35, 6-36, 6-37, 6-38, 6-39, 6-40
Modulation ON/OFF.....	6-6, 6-10, 6-11, 6-31, 6-45	Repeat Pattern	6-9
Modulator.....	6-10, 6-45	Step Size.....	6-10, 6-41
Modulator Cal Corr.....	6-45	Rx Control [R3562]	6-6
Modulator Cal Corr ON/OFF.....	6-10	Synthe Ref In	6-6, 6-10, 6-12, 6-42
Offset Value	6-10, 6-41	Unit	6-10, 6-41
Other.....	6-6, 6-42	Upper Limit.....	6-10, 6-41
Output ON/OFF	6-6, 6-10, 6-12, 6-31, 6-45	Walsh Len	6-26, 6-28, 6-30
Q Gain	6-10, 6-44	Walsh No.	6-26, 6-28, 6-30
PICH Setup	6-9, 6-32	[DCCH].....	6-6, 6-8, 6-17, 6-26
PN Offset.....	6-6, 6-14, 6-16	[FCH(A)].....	6-7, 6-8, 6-20, 6-25, 6-28
QOF.....	6-31	[FCH(B)].....	6-6, 6-7, 6-8, 6-17, 6-20, 6-22, 6-26, 6-28, 6-30
Parameter Setup	6-6, 6-11	[FCH(C)].....	6-7, 6-20, 6-28
Power Adjustment Ch.....	6-6, 6-7, 6-16, 6-19, 6-22	[I/Q Input]	6-10, 6-44
Power Control Pattern.....	6-9, 6-32	[I/Q Output]	6-10, 6-44
Preset.....	6-10, 6-45	[PICH].....	6-6, 6-7, 6-17, 6-19, 6-22
Primary Ch.(Eb).....	6-6, 6-7, 6-15, 6-16, 6-19, 6-22	[SCH(A)].....	6-7, 6-22, 6-30
Quit.....	6-6, 6-12, 6-45	[SCH(C)].....	6-7, 6-8,
SCH(TRCH A) Setup.....	6-9, 6-38		
SCH(TRCH C) Setup.....	6-9, 6-40		

	6-22, 6-30
[SCH1(C)].....	6-6, 6-17, 6-26
[SCH2(A)]	6-6, 6-8, 6-17, 6-26
[SYNCH]	6-7, 6-20, 6-22

6.2 Reference

6.2.2 Menu Map

A list of soft menus, which are under the ADVANCE key, used with the R3562 are shown below.

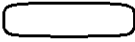
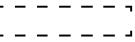
NOTE:  Represents a panel key.
 Represents a dialog box.
 Unless otherwise noted, the soft menus are shown.

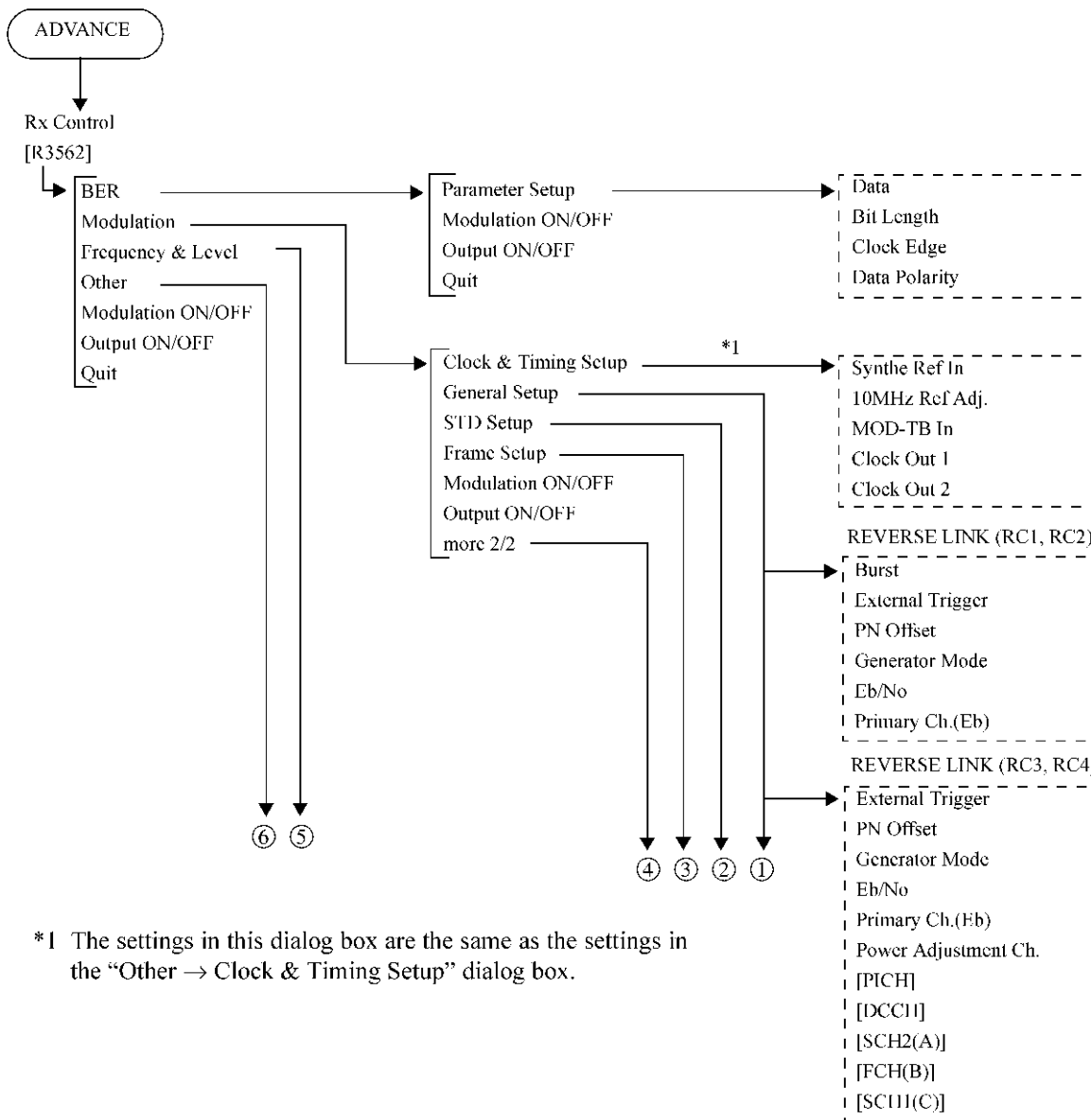

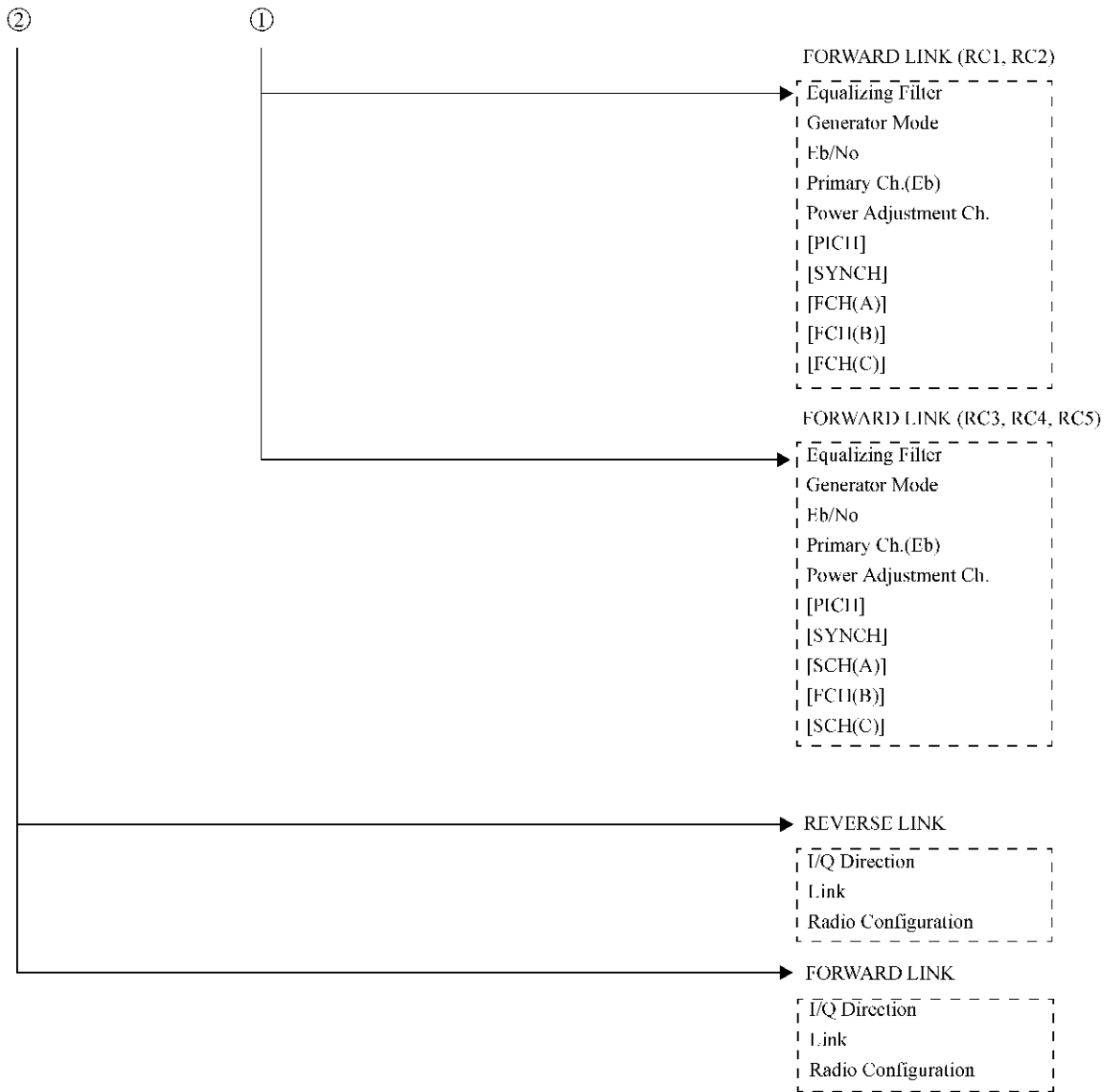

6.2 Reference

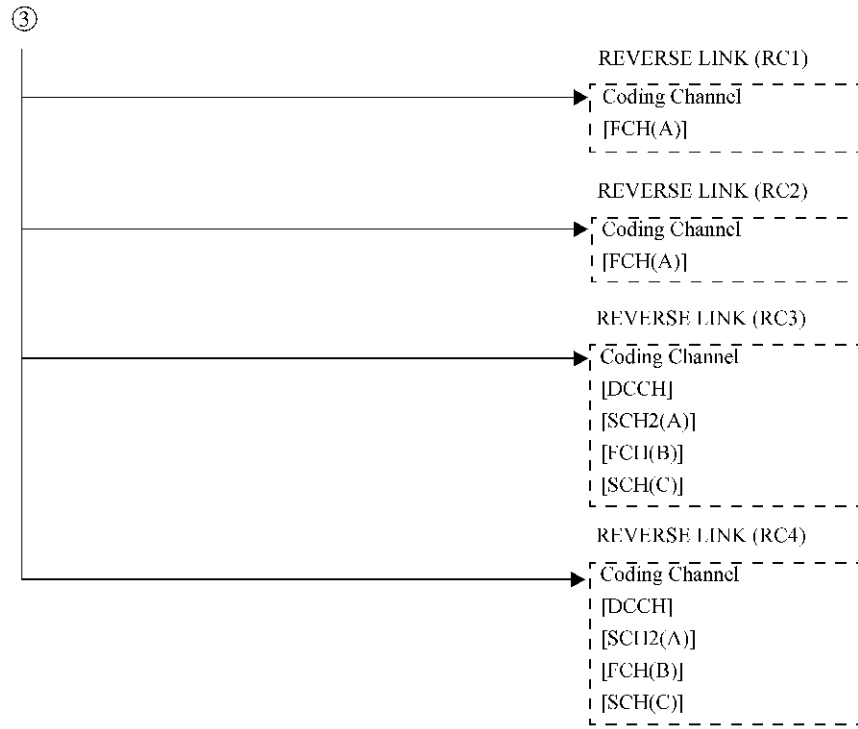

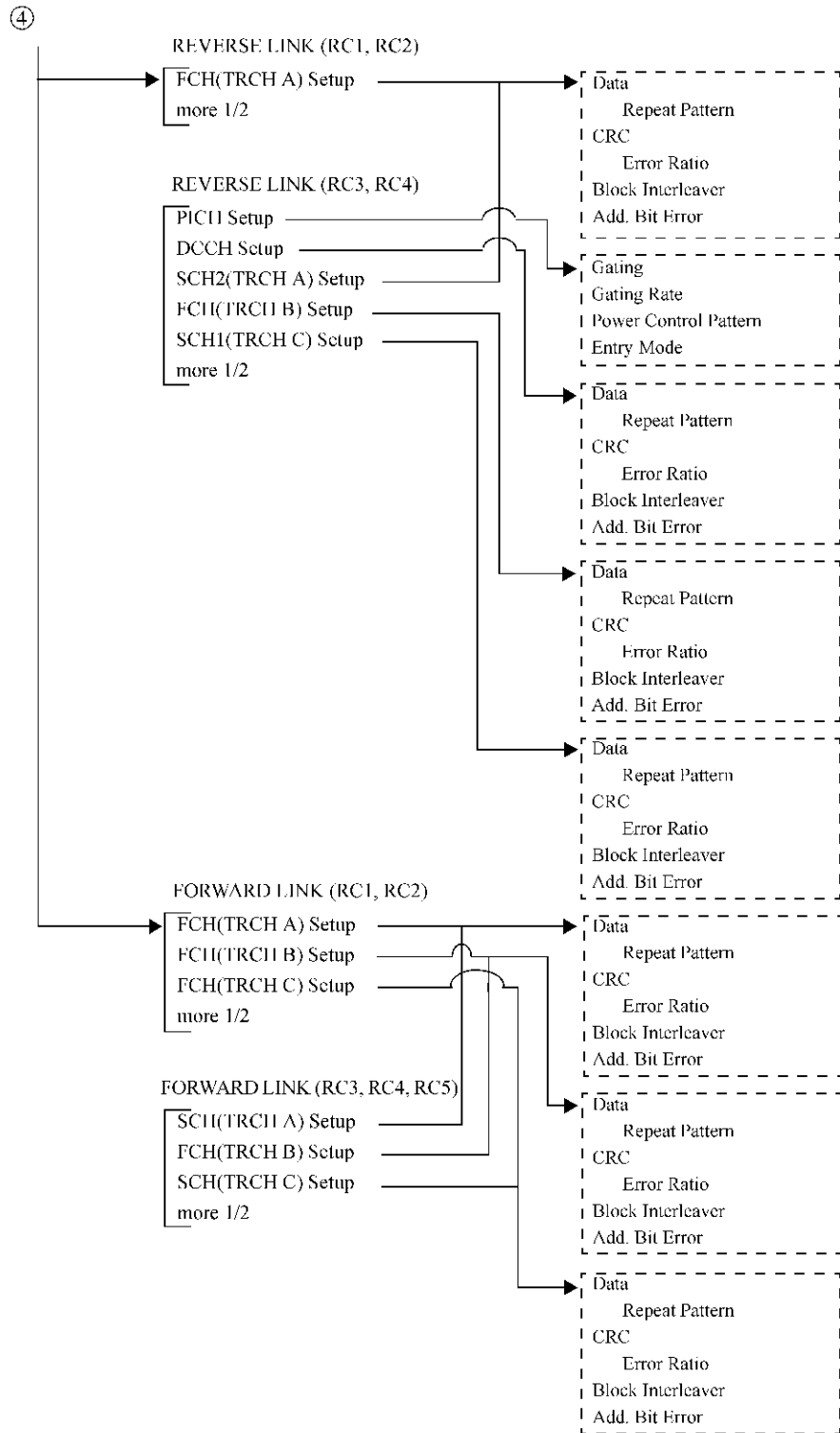

6.2 Reference

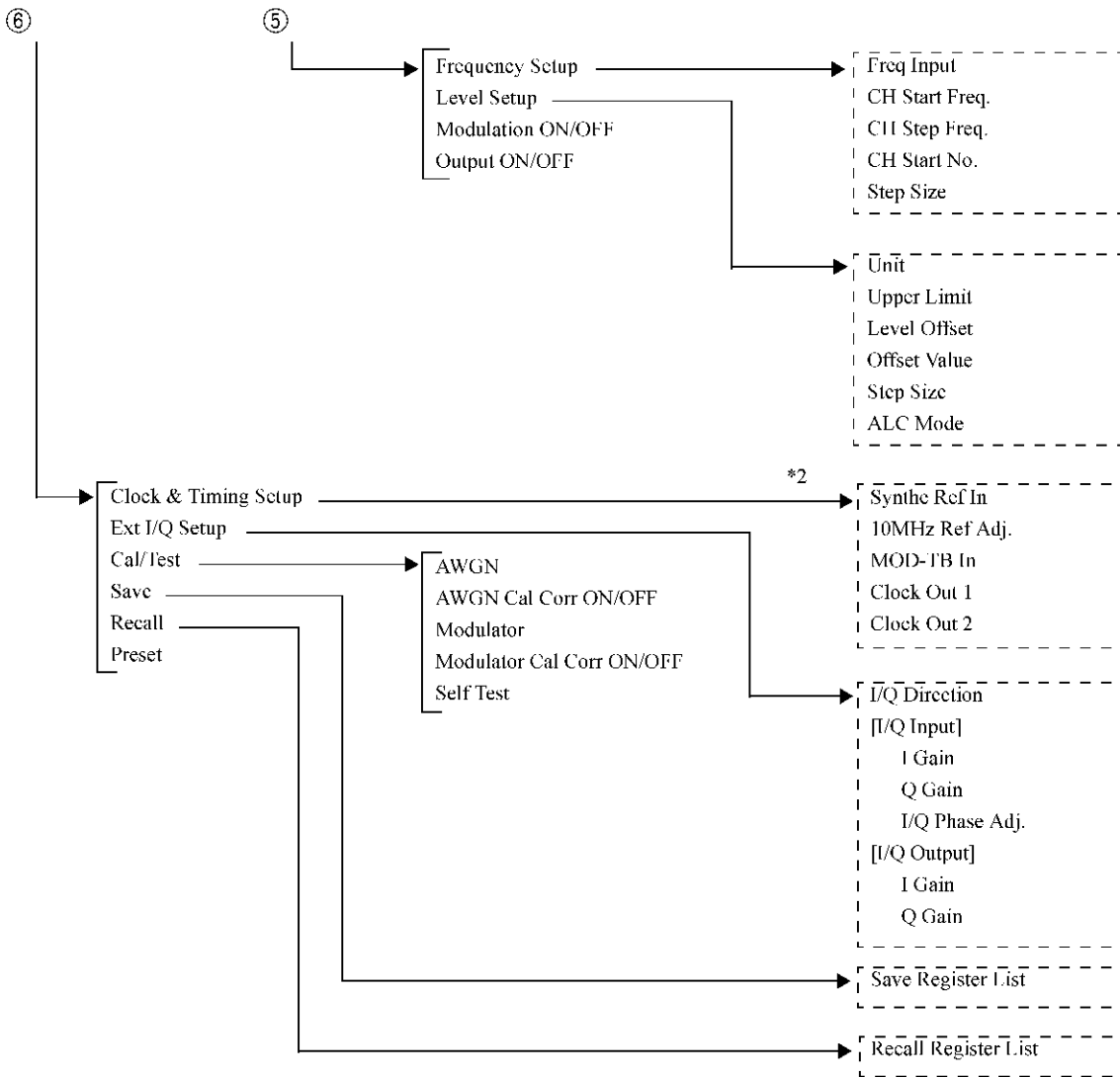

*2 The settings in this dialog box are the same as the settings in the “Modulation → Clock & Timing Setup” dialog box.

6.2.3 Functional Description

This section describes the front panel keys and the soft menus associated with them.

FREQ	A window prompting numeric values is displayed. Sets the output frequency. Use the up or down keys, the data knob and the numeric keys to enter data.
LEVEL	A window prompting numeric values is displayed. Used to set the output level. Use the up or down keys, the data knob and the numeric keys to enter data.
SINGLE	Makes one BER measurement.
REPEAT (START/STOP)	Makes repeated BER measurements, or stops the current BER measurement.
BER	Displays the BER Measurement Mode menu.
Parameter Setup	Displays the BER Parameter Setup dialog box.

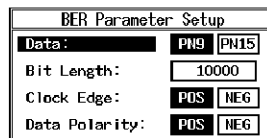

Figure 6-3 BER Parameter Setup Dialog Box

Data	Selects test data type. PN9: Selects PN9. PN15: Selects PN15.
Bit Length	Set BER measurement time with the bit length. The setting range of the bit length is 1000 to 10000000 bits.
Clock Polarity	Select from which edge you get data, the rising edge of the signal from BER clock terminal or the falling edge. POS: Rising NEG: Falling
Data Polarity	Select if you invert BER DATA terminal data or not. POS: Positive logic (not invert) NEG: Negative logic (invert)
Modulation ON/OFF	Turns the RF output modulation function on or off. ON: Modulates the RF output.

6.2 Reference

- Output ON/OFF**
 - OFF: Does not modulate the RF output.
 - Turns the RF output on or off.
 - ON: Turns the RF signal on.
 - OFF: Turns the RF signal off.
- Quit**
 - Exits from BER Measurement Mode.
- Modulation**
 - Displays the Mod. 1/2 menu.
- Clock & Timing Setup**
 - Displays the Clock/Timing Signal Parameter Setup dialog box.

Synth Ref In: [MHz]	1	1.2288	2	2.4576	4.9152
	5	9.8304	10	15	19.6608
	INTERNAL				
10MHz Ref Adj.:	0				
MOD-TB In: [MHz]	1	1.2288	2	2.4576	4.9152
	5	9.8304	10	15	19.6608
	INTERNAL				
Clock Out 1:	OFF	20mSec	26.6mSec	80mSec	
	2Sec	5mSec	CHIP CLOCK	EXT EVEN	
Clock Out 2:	OFF	20mSec	26.6mSec	80mSec	
	2Sec	5mSec	CHIP CLOCK	EXT EVEN	

Figure 6-4 Clock/Timing Signal Parameter Setup Dialog Box

- Synthe Ref In**
 - Selects the reference signal from the synthesizer.
 - 1 MHz: Uses an external signal of 1 MHz.
 - 1.2288 MHz: Uses an external signal of 1.2288 MHz.
 - 2 MHz: Uses an external signal of 2 MHz.
 - 2.4576 MHz: Uses an external signal of 2.4576 MHz.
 - 4.9152 MHz: Uses an external signal of 4.9152 MHz.
 - 5 MHz: Uses an external signal of 5 MHz.
 - 9.8304 MHz: Uses an external signal of 9.8304 MHz.
 - 10 MHz: Uses an external signal of 10 MHz.
 - 15 MHz: Uses an external signal of 15 MHz.
 - 19.6608 MHz: Uses an external signal of 19.6608 MHz.
 - INTERNAL: Uses the internal reference signal.
- 10MHz Ref Adj.**
 - Sets internal reference signal's frequency difference to be corrected.
- MOD-TB In**
 - Selects the reference signal used for the modulation.
 - 1 MHz: Uses an external signal of 1 MHz.
 - 1.2288 MHz: Uses an external signal of 1.2288 MHz.

2 MHz:	Uses an external signal of 2 MHz.
2.4576 MHz:	Uses an external signal of 2.4576 MHz.
4.9152 MHz:	Uses an external signal of 4.9152 MHz.
5 MHz:	Uses an external signal of 5 MHz.
9.8304 MHz:	Uses an external signal of 9.8304 MHz.
10 MHz:	Uses an external signal of 10 MHz.
15 MHz:	Uses an external signal of 15 MHz.
19.6608 MHz:	Uses an external signal of 19.6608 MHz.
INTERNAL:	Uses the internal reference signal.

Clock Out 1/Clock Out 2

Outputs the modulation timing signals to the CLOCK OUT1 and CLOCK OUT2 connectors.

OFF:	Turns the output signal off.
20 msec:	Outputs the signals for the Traffic Channel frame period.
26.6 msec:	Outputs the signals for the Sync Channel frame period.
80 msec:	Outputs the signals for the Sync Channel super frame period.
2 sec:	Outputs the even-second signal in the base band block.
5 msec:	Outputs the signals for both the FCH and DCCH Channel frame periods.
CHIP CLOCK:	Outputs a chip clock of 1.2288 MHz.
EXT EVEN:	Outputs an even-second signal which is input to the EXT TRIG terminal.

<When Reverse Is Set to RC1 or RC2>

General Setup

The General Parameter Setup <Reverse: RC1/RC2> dialog box is displayed if Reverse RC1 or RC2 is selected in the STD Parameter Setup dialog box shown in Figure 6-9.

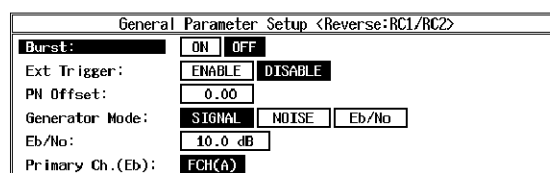

**Figure 6-5 General Parameter Setup Dialog Box
<When Reverse Is Set to RC 1 or RC 2>**

6.2 Reference

<i>Burst</i>	<p>Toggles the Fundamental Channel burst on or off.</p> <p>ON: Turns the burst on.</p> <p>OFF: Turns the burst off.</p> <hr/> <p>NOTE: <i>The burst is automatically turned off when Radio Configuration is set to 3 or 4.</i></p> <hr/>
<i>EXT Trigger</i>	<p>Sets whether or not the baseband block of this instrument is synchronized with the even-second signal input to the EXT TRIG IN terminal on the front panel.</p> <p>ENABLE: The baseband block is synchronized with the even-second signal input to the EXT TRIG IN terminal.</p> <p>DISABLE: The baseband block is not synchronized with the even-second signal input to the EXT TRIG IN terminal.</p> <hr/> <p>NOTE: <i>No signal is output from the RF OUT connector if the EXT Trigger is set to ENABLE but the even-second signal is not input to the EXT TRIG IN connector. In addition, the R3562 may not be synchronized with the base station unless the frequency synchronization between the two is maintained using MOD TIME BASE IN or SYN-THE REFIN.</i></p> <hr/>
<i>PN Offset</i>	<p>Sets a PN offset value for the even-second signal if EXT Trigger is set to ENABLE and the instrument is synchronized with the even-second signal.</p> <p>One PN offset is 64 chips. As a result, the relationship between the chip quantity and the PN offset setting value is as shown below:</p> <p>OFFSET [in chips] = Round-off (64 × PN OFFSET)</p> <p>OFFSET [in chips]: Quantity (in chips) set to this instrument.</p> <p>PN OFFSET: Setting value for the PN offset</p> <p>Round-off: Rounded off at the first decimal place.</p>
<i>Generator Mode</i>	<p>Selects a signal input to the IQ modulator.</p> <p>SIGNAL: Selects a CDMA signal.</p> <p>NOISE: Selects an AWGN signal with a bandpass of 2 MHz.</p> <p>Eb/No: Selects a CDMA signal combined with the AWGN output signal. A ratio of the primary channel signal level to the AWGN output level is set.</p>

NOTE: First perform an AWGN calibration before setting the generator mode to Eb/No.

Eb/No Sets an Eb/No(Nt) value for the primary channel.

Primary Ch.(Eb) The primary channel is fixed for Radio Configuration 1 or 2.

<When Reverse Is Set to RC3 or RC4>

General Setup

The General Parameter Setup <Reverse: RC3/RC4> dialog box is displayed if Reverse RC3 or RC4 is selected in the STD Parameter Setup dialog box shown in Figure 6-9.

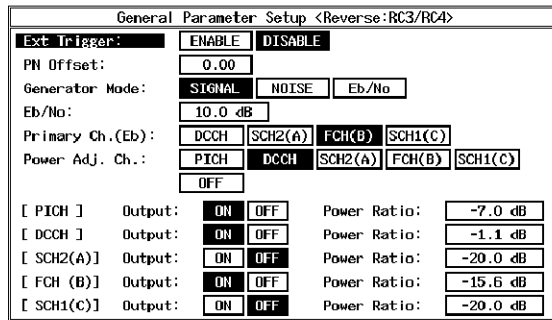

Figure 6-6 General Parameter Setup Dialog Box
 <When Reverse Is Set to RC 3 or RC 4>

EXT Trigger

Sets whether or not the baseband block of this instrument is synchronized with the even-second signal input to the EXT TRIG IN terminal on the front panel.

ENABLE: The baseband block is synchronized with the even-second signal input to the EXT TRIG IN terminal.

DISABLE: The baseband block is not synchronized with the even-second signal input to the EXT TRIG IN terminal.

NOTE: No signal is output from the RF OUT connector if the EXT Trigger is set to ENABLE but the even-second signal is not input to the EXT TRIG IN connector. In addition, the R3562 may not be synchronized with the base station unless the frequency synchronization between the two is maintained using MOD TIME BASE IN or SYN- THE REFIN.

6.2 Reference

PN Offset Sets a PN offset value for the even-second signal if EXT Trigger is set to ENABLE and the instrument is synchronized with the even-second signal.
 One PN offset is 64 chips. As a result, the relationship between the chip quantity and the PN offset setting value is as shown below:

$$\text{OFFSET [in chips]} = \text{Round-off} (64 \times \text{PN OFFSET})$$
 OFFSET [in chips]: Quantity (in chips) set to this instrument.
 PN OFFSET: Setting value for the PN offset
 Round-off: Rounded off at the first decimal place.

Generator Mode Selects a signal input to the IQ modulator.
 SIGNAL: Selects a CDMA signal.
 NOISE: Selects an AWGN signal with a bandpass of 2 MHz.
 Eb/No: Selects a CDMA signal combined with the AWGN output signal.
 A ratio of the primary channel signal level to the AWGN output level is set.

NOTE: *First perform an AWGN calibration before setting the generator mode to Eb/No.*

Eb/No Sets an Eb/No(Nt) value for the primary channel.

Primary Ch.(Eb) Sets the primary channel to Control Channel, Traffic Channel A, Traffic Channel B or Traffic Channel C whose output is turned on. The selected channel is used as the target channel of Eb/No(Nt).

- DCCH: Selects Dedicated Control Channel as the primary channel.
- SCH2(A): Selects Supplemental Channel 2 as the primary channel.
- FCH(B): Selects Fundamental Channel as the primary channel.
- SCH1(C): Selects Supplemental Channel 1 as the primary channel.

Power Adjustment Ch.
 Selects the output supplemental channel from the channels whose outputs are turned on. The output of the selected channel is automatically adjusted so that the sum total of all output channels is 0 dB.

PICH:	Selects Pilot Channel as the output supplemental channel.
DCCH:	Selects Dedicated Control Channel as the output supplemental channel.
SCH2(A):	Selects Supplemental Channel 2 as the output supplemental channel.
FCH(B):	Selects Fundamental Channel as the output supplemental channel.
SCH1(C):	Selects Supplemental Channel 1 as the output supplemental channel.
OFF	Turns the output level supplemental channel off.
[PICH]	Turns the Pilot Channel output on or off, and sets Power Ratio.
[DCCH]	Turns the Dedicated Control Channel output on or off, and sets Power Ratio.
[SCH2(A)]	Turns Supplemental Channel 2 output on or off, and sets Power Ratio.
[FCH(B)]	Turns the Fundamental Channel output on or off, and sets Power Ratio.
[SCH1(C)]	Turns the Supplemental Channel 1 output on or off, and sets Power Ratio.

NOTE:

1. *The output of the channel selected as the primary channel cannot be turned off.*
2. *The output of the channel selected as the output level supplemental channel cannot be turned off.*
3. *After the output level supplemental channel has been selected, a channel level setting cannot be changed if the sum total of all the output channels exceeds 0 dB, and any channel whose output is currently turned off cannot be turned on.*
4. *If PICH, DCCH, SCH2(A), FCH(B) or SCH1(C) is selected as an output level supplemental channel, the output setting value for each channel is a value relative to the sum total of all channel levels.
If the output level supplemental channel is not selected (or off), the output setting value for each channel is a value relative to a specific channel.
Example:
If the output level supplemental channel is not selected (or off) All channels have the same output level for Cases "a" and "b" in Table 6-1.*

6.2 Reference

Table 6-1 Example 1 showing when the Output Level Supplemental Channel is OFF

Channel	Case a	Case b
Pilot Channel	-5dB	-10dB
Dedicated Control Channel	-5dB	-10dB
Supplemental Channel 2(A)	-5dB	-10dB

- If the output level supplemental channel is not selected (or off), any channel level that is 20 dB or more than the sum total channel power cannot be set.

Example:

Table 6-2 shows the channel level limit values.

Table 6-2 Example 2 showing when the Output Level Supplemental Channel is OFF

Channel	Setting level	Limit value
Pilot Channel	-1.9dB	Upper limit value
Dedicated Control Channel	-2.0dB	Upper limit value
Supplemental Channel 2(A)	-18.9dB	Lower limit value

<When Forward Is Set to RC1 or RC2>

General Setup

The General Parameter Setup <Forward: RC1/RC2> dialog box is displayed if Forward RC 1 or RC2 is selected in the STD Parameter Setup dialog box shown in Figure 6-9.

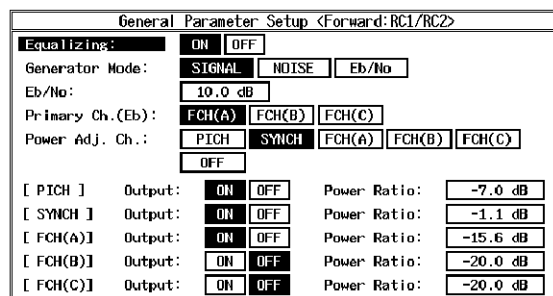

Figure 6-7 General Parameter Setup Dialog Box <When Forward Is Set to RC 1 or RC 2>

<i>Equalizing</i>	Turns Equalizing Filter on or off.
<i>Generator Mode</i>	Selects a signal input to the IQ modulator.
SIGNAL:	Selects a CDMA signal.
NOISE:	Selects an AWGN signal with a bandpass of 2 MHz.
Eb/No:	Selects a CDMA signal combined with the AWGN output signal. A ratio of the primary channel signal level to the AWGN output level is set.

NOTE: *First perform an AWGN calibration before setting the generator mode to Eb/No.*

<i>Eb/No</i>	Sets an Eb/No(Nt) value for the primary channel.
<i>Primary Ch.(Eb)</i>	Selects the primary channel from the Traffic channels A, B and C with the outputs turned on. The selected channel is used as the target channel of Eb/No(Nt).
FCH(A):	Selects Fundamental Channel(A) as the primary channel.
FCH(B):	Selects Fundamental Channel(B) as the primary channel.
FCH(C):	Selects Fundamental Channel(C) as the primary channel.

Power Adjustment Ch.

Selects the output supplemental channel from the channels whose outputs are turned on. The output of the selected channel is automatically adjusted so that the sum total of all output channels is 0 dB.

PICH:	Selects Pilot Channel as the output supplemental channel.
SYNCH:	Selects Sync Channel as the output supplemental channel.
FCH(A):	Selects Fundamental Channel(A) as the output supplemental channel.
FCH(B):	Selects Fundamental Channel(B) as the output supplemental channel.
FCH(C):	Selects Fundamental Channel(C) as the output supplemental channel.
OFF	Turns the output level supplemental channel off.

[PICH] Turns the Pilot Channel output on or off, and sets Power Ratio.

6.2 Reference

- [SYNCH]** Turns the Sync Channel output on or off, and sets Power Ratio.
- [FCH(A)]** Turns the Fundamental Channel(A) output on or off, and sets Power Ratio.
- [FCH(B)]** Turns the Fundamental Channel(B) output on or off, and sets Power Ratio.
- [FCH(C)]** Turns the Fundamental Channel(C) output on or off, and sets Power Ratio.

NOTE:

1. *The output of the channel selected as the primary channel cannot be turned off.*
2. *The output of the channel selected as the output level supplemental channel cannot be turned off.*
3. *After the output level supplemental channel has been selected, a channel level setting cannot be changed if the sum total of all the output channels exceeds 0 dB, and any channel whose output is currently turned off cannot be turned on.*
4. *If PICH, SYNCH, FCH(A), FCH(B) or FCH(C) is selected as an output level supplemental channel, the output setting value for each channel is a value relative to the sum total of all channel levels.*

If the output level supplemental channel is not selected (or off), the output setting value for each channel is a value relative to a specific channel.

Example:

If the output level supplemental channel is not selected (or off) All channels have the same output level for Cases “a” and “b” in Table 6-3.

Table 6-3 Example 1 showing when the Output Level Supplemental Channel is OFF

Channel	Case a	Case b
Pilot Channel	-5dB	-10dB
Sync Channel	-5dB	-10dB
Fundamental Channel(A)	-5dB	-10dB

5. *If the output level supplemental channel is not selected (or off), any channel level that is 20 dB or more than the sum total channel power cannot be set.*

Example:

Table 6-4 shows the channel level limit values.

Table 6-4 Example 2 showing when the Output Level Supplemental Channel is OFF

Channel	Setting level	Limit value
Pilot Channel	-1.9dB	Upper limit value
Sync Channel	-2.0dB	Upper limit value
Fundamental Channel(A)	-18.9dB	Lower limit value

<When Forward Is Set to RC3, RC4 or RC5>

General Setup

The General Parameter Setup <Forward: RC3/RC4/RC5> dialog box is displayed if Forward RC3, RC4 or RC5 is selected in the STD Parameter Setup dialog box shown in Figure 6-9.

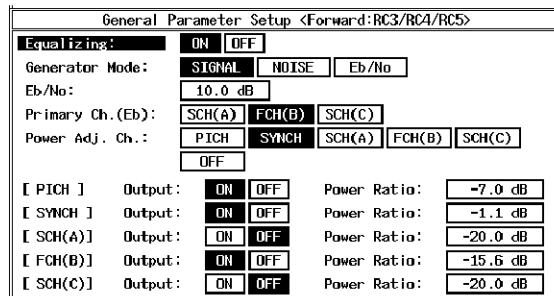

Figure 6-8 General Parameter Setup Dialog Box <When Forward Is Set to RC 3, RC4 or RC5>

Equalizing

Turns Equalizing Filter on or off.

Generator Mode

Selects a signal input to the IQ modulator.

SIGNAL: Selects a CDMA signal.

NOISE: Selects an AWGN signal with a bandpass of 2 MHz.

Eb/No: Selects a CDMA signal combined with the AWGN output signal.

A ratio of the primary channel signal level to the AWGN output level is set.

NOTE: First perform an AWGN calibration before setting the generator mode to Eb/No.

6.2 Reference

<i>Eb/No</i>	Sets an Eb/No(Nt) value for the primary channel.
<i>Primary Ch.(Eb)</i>	Selects the primary channel from the Traffic channels A, B and C with the outputs turned on. The selected channel is used as the target channel of Eb/No(Nt).
SCH(A):	Selects Supplemental Channel(A) as the primary channel.
FCH(B):	Selects Fundamental Channel(B) as the primary channel.
SCH(C):	Selects Supplemental Channel(C) as the primary channel.

Power Adjustment Ch.

Selects the output supplemental channel from the channels whose outputs are turned on. The output of the selected channel is automatically adjusted so that the sum total of all output channels is 0 dB.

PICH:	Selects Pilot Channel as the output supplemental channel.
SYNCH:	Selects Sync Channel as the output supplemental channel.
SCH(A):	Selects Supplemental Channel(A) as the output supplemental channel.
FCH(B):	Selects Fundamental Channel(B) as the output supplemental channel.
SCH(C):	Selects Supplemental Channel(C) as the output supplemental channel.
OFF	Turns the output level supplemental channel off.

<i>[PICH]</i>	Turns the Pilot Channel output on or off, and sets Power Ratio.
<i>[SYNCH]</i>	Turns the Sync Channel output on or off, and sets Power Ratio.
<i>[SCH(A)]</i>	Turns the Supplemental Channel(A) output on or off, and sets Power Ratio.
<i>[FCH(B)]</i>	Turns the Fundamental Channel(B) output on or off, and sets Power Ratio.
<i>[SCH(C)]</i>	Turns the Supplemental Channel(C) output on or off, and sets Power Ratio.

NOTE:

1. *The output of the channel selected as the primary channel cannot be turned off.*

2. *The output of the channel selected as the output level supplemental channel cannot be turned off.*
3. *After the output level supplemental channel has been selected, a channel level setting cannot be changed if the sum total of all the output channels exceeds 0 dB, and any channel whose output is currently turned off cannot be turned on.*
4. *If PICH, SYNCII, SCII(A), FCII(B) or SCII(C) is selected as an output level supplemental channel, the output setting value for each channel is a value relative to the sum total of all channel levels.*

If the output level supplemental channel is not selected (or off), the output setting value for each channel is a value relative to a specific channel.

Example:

If the output level supplemental channel is not selected (or off) All channels have the same output level for Cases "a" and "b" in Table 6-5.

Table 6-5 Example 1 showing when the Output Level Supplemental Channel is OFF

Channel	Case a	Case b
Pilot Channel	-5dB	-10dB
Sync Channel	-5dB	-10dB
Supplemental Channel(A)	-5dB	-10dB

5. *If the output level supplemental channel is not selected (or off), any channel level that is 20 dB or more than the sum total channel power cannot be set.*

Example:

Table 6-6 shows the channel level limit values.

Table 6-6 Example 2 showing when the Output Level Supplemental Channel is OFF

Channel	Setting level	Limit value
Pilot Channel	-1.9dB	Upper limit value
Sync Channel	-2.0dB	Upper limit value
Supplemental Channel(A)	-18.9dB	Lower limit value

6.2 Reference

STD Setup

Displays the STD Parameter setup dialog box.

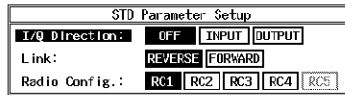

Figure 6-9 STD Parameter Setup Dialog box

I/Q Direction

Exchanges the external IQ terminals between the input and output and selects the IQ signal paths to the IQ modulator.

OFF: Turns off the IQ output, and inputs the internal baseband signal to the IQ modulator.

INPUT: The IQ signal coming from the outside is input to the IQ modulator.

OUTPUT: Turns on the IQ output to be sent to the outside.

Link

Selects the link direction.

REVERSE: Outputs the Reverse Link signal.

FORWARD: Outputs the Forward Link signal.

Radio Configuration

Specifies the Radio Configuration numbers prescribed by IS2000.

<When Reverse Is Set to RC1 or RC2>

Frame Setup

Refer to the STD Parameter Setup dialog box shown in Figure 6-9. If Reverse RC1 is selected the Frame Parameter Setup <Reverse: RC1> dialog box is displayed.

If Reverse RC2 is selected the Frame Parameter Setup <Reverse: RC2> dialog box is displayed.

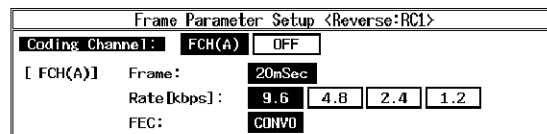

Figure 6-10 Frame Parameter Setup Dialog Box <When Reverse Is Set to RC 1>

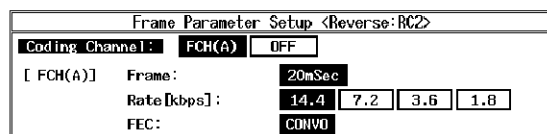

Figure 6-11 Frame Parameter Setup Dialog Box <When Reverse Is Set to RC 2>

Coding Channel

Selects whether realtime coding is performed on FCH or not.

[FCH(A)]

- Frame** The frame length is fixed at 20 msec for RC1 or RC2.
- Rate** Selects Data Rate.
- FEC** Fixed at Convolutional for RC1 or RC2.

NOTE: The selection range for each parameter complies with the associated standards. Refer to Section 2.3, "cdma Function" and Section 3.2, "Channel Setup" of R3562 OPT65 OPERATION MANUAL.

<When Reverse Is Set to RC3 or RC4>

Frame Setup

Refer to the STD Parameter Setup dialog box shown in Figure 6-9. If Reverse RC3 is selected the Frame Parameter Setup <Reverse: RC3> dialog box is displayed. If Reverse RC4 is selected the Frame Parameter Setup <Reverse: RC4> dialog box is displayed.

Coding Channel:		DCCH	SCH2(A)	FCH(B)	SCH1(C)	OFF
[DCCH]	Frame:	5mSec	20mSec			
76.8 kbps	Rate [kbps]:	9.6				
	Walsh Len.:	16		Walsh No.:	8	
	FEC:	CONVO				
[SCH2(A)]	Frame:	20mSec	40mSec	80mSec		
76.8 kbps	Rate [kbps]:	76.8	38.4	19.2	9.6	4.8
		2.7	1.5			
	Walsh Len.:	4	8		Walsh No.:	2
	FEC:	CONVO	TURBO			
[FCH(B)]	Frame:	5mSec	20mSec			
76.8 kbps	Rate [kbps]:	9.6	4.8	2.7	1.5	
	Walsh Len.:	16		Walsh No.:	4	
	FEC:	CONVO				
[SCH1(C)]	Frame:	20mSec	40mSec	80mSec		
76.8 kbps	Rate [kbps]:	307.2	153.6	76.8	38.4	19.2
		9.6	4.8	2.7	1.5	
	Walsh Len.:	2	4		Walsh No.:	1
	FEC:	CONVO	TURBO			

Figure 6-12 Frame Parameter Setup Dialog Box
<When Reverse Is Set to RC 3>

6.2 Reference

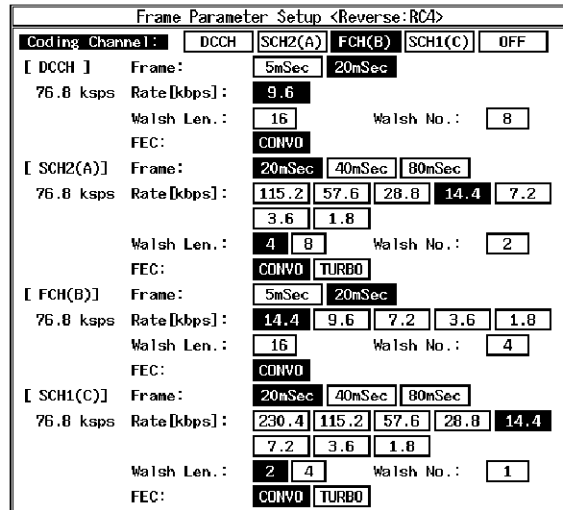

Figure 6-13 Frame Parameter Setup Dialog Box
 <When Reverse Is Set to RC 4>

- Coding Channel** Selects a channel on which realtime coding is performed.
- DCCH: Performs realtime coding for Dedicated Control Channel.
 - SCH2(A): Performs realtime coding for Supplemental 2 Channel.
 - FCH(B): Performs realtime coding for Fundamental Channel.
 - SCH1(C): Performs realtime coding for Supplemental 1 Channel.
 - OFF: Turns realtime coding function off for each channel.

NOTE: *Realtime coding is performed on one channel at a time. As a previously selected channel is removed from the target, only the currently selected channel is targeted for realtime coding.*

[DCCH], [SCH2(A)], [FCH(B)] and [SCH1(C)]

- Frame** Selects Frame Length.
- Rate** Selects Data Rate.
- Walsh Len** Selects the Walsh length.
- Walsh No.** Selects the Walsh number.

FEC Selects either Turbo Coding or Convolutional Coding.

NOTE: The range for each parameter is prescribed by the standard. For more information, refer to Section 2.3, “cdma2000 Function” and Section 3.2, “Channel Setup” in “R3562 OPT65 OPERATING MANUAL.”

<When Forward Is Set to RC1 or RC2>

Frame Setup

Refer to the STD Parameter Setup dialog box shown in Figure 6-9. If Forward RC1 is selected the Frame Parameter Setup <Forward: RC1> dialog box is displayed.

If Forward RC2 is selected the Frame Parameter Setup <Forward: RC2> dialog box is displayed.

Coding Channel:		FCH(A)	FCH(B)	FCH(C)	OFF
[FCH(A)]	Frame:	20mSec			
	Rate[kbps]:	9.6	4.8	2.4	1.2
	Walsh Len.:	64		Walsh No.: 8	
	FEC:	CONVQ			
[FCH(B)]	Frame:	20mSec			
	Rate[kbps]:	9.6	4.8	2.4	1.2
	Walsh Len.:	64		Walsh No.: 62	
	FEC:	CONVQ			
[FCH(C)]	Frame:	20mSec			
	Rate[kbps]:	9.6	4.8	2.4	1.2
	Walsh Len.:	64		Walsh No.: 63	
	FEC:	CONVQ			

Figure 6-14 Frame Parameter Setup Dialog Box <When Forward Is Set to RC 1>

Coding Channel:		FCH(A)	FCH(B)	FCH(C)	OFF
[FCH(A)]	Frame:	20mSec			
	Rate[kbps]:	14.4	7.2	3.6	1.8
	Walsh Len.:	64		Walsh No.: 8	
	FEC:	CONVQ			
[FCH(B)]	Frame:	20mSec			
	Rate[kbps]:	14.4	7.2	3.6	1.8
	Walsh Len.:	64		Walsh No.: 62	
	FEC:	CONVQ			
[FCH(C)]	Frame:	20mSec			
	Rate[kbps]:	14.4	7.2	3.6	1.8
	Walsh Len.:	64		Walsh No.: 63	
	FEC:	CONVQ			

Figure 6-15 Frame Parameter Setup Dialog Box <When Forward Is Set to RC2>

Coding Channel Selects a channel on which realtime coding is performed.

6.2 Reference

FCH(A):	Performs realtime coding for Fundamental Channel(A).
FCH(B):	Performs realtime coding for Fundamental Channel(B).
FCH(C):	Performs realtime coding for Fundamental Channel(C).
OFF:	Turns realtime coding function off for each channel.

NOTE: *Realtime coding is performed on one channel at a time. As a previously selected channel is removed from the target, only the currently selected channel is targeted for realtime coding.*

[FCH(A)], [FCH(B)], [FCH(C)]

Frame	Selects Frame Length.
Rate	Selects Data Rate.
Walsh Len	Selects Walsh Length.
Walsh No.	Selects Walsh Number.
FEC	RC1 and RC2 are fixed at Convolutional.

NOTE: *The selection range for each parameter complies with the associated standards. Refer to Section 2.3, "cdma Function" and Section 3.2, "Channel Setup" of R3562 OPT65 OPERATION MANUAL.*

<When Forward Is Set to RC3, RC4 or RC5>

Frame Setup

Refer to the STD Parameter Setup dialog box shown in Figure 6-9. If Forward RC3 is selected the Frame Parameter Setup <Forward: RC3> dialog box is displayed.
 If Forward RC4 is selected the Frame Parameter Setup <Forward: RC4> dialog box is displayed.
 If Forward RC5 is selected the Frame Parameter Setup <Forward: RC5> dialog box is displayed.

Coding Channel:		SCH(A)	FCH(B)	SCH(C)	OFF
[SCH(A)]	Frame:	20mSec	40mSec	80mSec	
38.4 kbps	Rate [kbps]:	153.6	76.8	38.4	19.2 9.6
		4.8	2.7	1.5	
	Walsh Len.:	64			Walsh No.: 62
	FEC:	CONVO	TURBO		
	QOF:	0	1	2	3
[FCH(B)]	Frame:	5mSec	20mSec		
38.4 kbps	Rate [kbps]:	9.6	4.8	2.7	1.5
	Walsh Len.:	64			Walsh No.: 8
	FEC:	CONVO			
	QOF:	0	1	2	3
[SCH(C)]	Frame:	20mSec	40mSec	80mSec	
38.4 kbps	Rate [kbps]:	153.6	76.8	38.4	19.2 9.6
		4.8	2.7	1.5	
	Walsh Len.:	64			Walsh No.: 63
	FEC:	CONVO	TURBO		
	QOF:	0	1	2	3

Figure 6-16 Frame Parameter Setup Dialog Box
<When Forward Is Set to RC3>

Coding Channel:		SCH(A)	FCH(B)	SCH(C)	OFF
[SCH(A)]	Frame:	20mSec	40mSec	80mSec	
19.2 kbps	Rate [kbps]:	307.2	153.6	76.8	38.4 19.2
		9.6	4.8	2.7	1.5
	Walsh Len.:	128			Walsh No.: 126
	FEC:	CONVO	TURBO		
	QOF:	0	1	2	3
[FCH(B)]	Frame:	5mSec	20mSec		
19.2 kbps	Rate [kbps]:	9.6	4.8	2.7	1.5
	Walsh Len.:	128			Walsh No.: 8
	FEC:	CONVO			
	QOF:	0	1	2	3
[SCH(C)]	Frame:	20mSec	40mSec	80mSec	
19.2 kbps	Rate [kbps]:	307.2	153.6	76.8	38.4 19.2
		9.6	4.8	2.7	1.5
	Walsh Len.:	128			Walsh No.: 127
	FEC:	CONVO	TURBO		
	QOF:	0	1	2	3

Figure 6-17 Frame Parameter Setup Dialog Box
<When Forward Is Set to RC4>

6.2 Reference

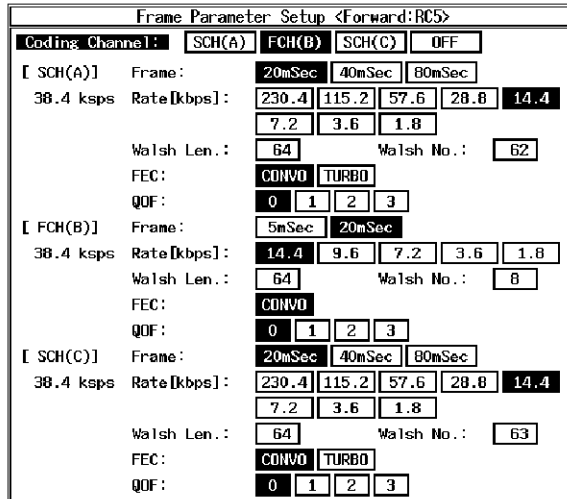

Figure 6-18 Frame Parameter Setup Dialog Box
<When Forward Is Set to RC5>

- Coding Channel** Selects a channel on which realtime coding is performed.
- SCH(A): Performs realtime coding for Supplemental Channel(A).
 - FCH(B): Performs realtime coding for Fundamental Channel(B).
 - SCH(C): Performs realtime coding for Supplemental Channel(C).
 - OFF: Turns realtime coding function off for each channel.

NOTE: *Realtime coding is performed on one channel at a time. As a previously selected channel is removed from the target, only the currently selected channel is targeted for realtime coding.*

[SCH(A)], [FCH(B)], [SCH(C)]

- Frame** Selects Frame Length.
- Rate** Selects Data Rate.
- Walsh Len** Selects Walsh Length.
- Walsh No.** Selects Walsh Number.
- FEC** Selects either Turbo or Convolutional Coding.

QOF Quasi Orthogonal Spreading can be performed using Forward Link RC3, RC4 or RC5. Select Functions 0 thru 3 which conform to the associated standards.

NOTE: *The selection range for each parameter complies with the associated standards. Refer to Section 2.3, "cdma Function" and Section 3.2, "Channel Setup" of R3562 OPT65 OPERATION MANUAL.*

Modulation ON/OFF Turns the RF output modulation function on or off.
 ON: Modulates the RF output.
 OFF: Does not modulate the RF output.

Output ON/OFF Turns the RF output on or off.
 ON: Turns the RF signal on.
 OFF: Turns the RF signal off.

more 2/2 Displays Mod. (2/2) Menu.
 The menus for Link and Radio Configuration differ.

<When Reverse Is Set to RC1 or RC2>

FCH(TRCH A) Setup Displays the Traffic Channel A Parameter Setup dialog box.

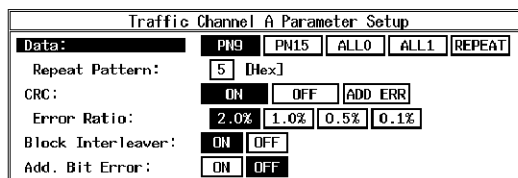

Figure 6-19 Traffic Channel A Parameter Setup Dialog Box

DATA Selects the data pattern input to the realtime coder (Information data) or the data pattern input to the spreading section (Physical data).

- PN9: Selects a 9-stage PN code data pattern.
- PN15: Selects a 15-stage PN code data pattern.
- ALL0: Selects all zero data.
- ALL1: Selects all one data.
- REP.: Selects a data pattern consisting of the arbitrarily set four bits.

Rep. Pattern Specifies a value [in hexadecimal] for the arbitrarily set four bits.

CRC Selects a type of CRC to be added to the channel data.

6.2 Reference

- ON: Sets each CRC value correctly.
- OFF: Sets each CRC value to 0.
- ADD ERR: Adds an error to each CRC.

Error Ratio Selects an error ratio that is added to CRC.

Block Interleaver Toggles the Block Interleaving function on or off.

Add. Bit Error Selects whether or not an error of 1% is added to the Information or Physical data pattern.

<When Reverse Is Set to RC3 or RC4>

PICH Setup Displays the PICH Parameter Setup Dialog Box.

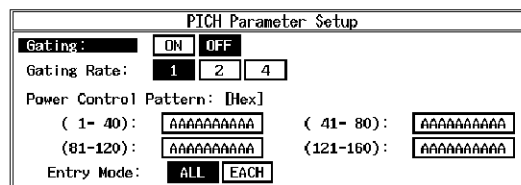

Figure 6-20 PICH Parameter Setup Dialog Box

Gating Toggles the gating function for Reserve Pilot Channel on or off. When it is turned on, Power Control Channel is enabled, and Power Control Bit is inserted. When it is turned off, Power Control Channel is disabled, and Power Control Bit is always 0 (zero).

Gating Rate Sets the gating rate of Reverse Pilot Channel.

- 1: Sets Gating Rate to 1.
- 2: Sets Gating Rate to 1/2.
- 4: Sets Gating Rate to 1/4.

Power Control Pattern Specifies the bit pattern [in hexadecimal notation] of the Reverse Power Control Subchannel for Radio Configuration 3 or 4.

Entry Mode Selects the input mode for the power control pattern.

- ALL: Once you enter one character, all other characters are set to the same character.
- EACH: Up to 40 characters are entered.

<When Reverse Is Set to RC3 or RC4>

DCCH Setup Displays the DCCH Parameter Dialog Box.

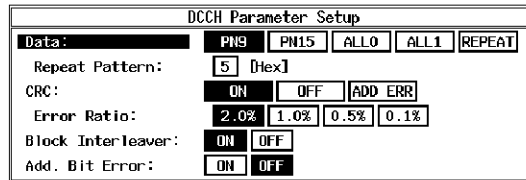

Figure 6-21 DCCH Parameter Setup Dialog Box

DATA

Selects the data pattern input to the realtime coder (Information data) or the data pattern input to the spreading section (Physical data).

PN9: Selects a 9-stage PN code data pattern.

PN15: Selects a 15-stage PN code data pattern.

ALL0: Selects all zero data.

ALL1: Selects all one data.

REP.: Selects a data pattern consisting of the arbitrarily set four bits.

Rep. Pattern

Specifies a value [in hexadecimal] for the arbitrarily set four bits.

CRC

Selects a type of CRC to be added to the channel data.

ON: Sets each CRC value correctly.

OFF: Sets each CRC value to 0.

ADD ERR: Adds an error to each CRC.

Error Ratio

Selects an error ratio that is added to CRC.

Block Interleaver

Toggles the Block Interleaving function on or off.

Add. Bit Error

Selects whether or not an error of 1% is added to the Information or Physical data pattern.

<When Reverse Is Set to RC3 or RC4>

SCH2(TRCH A) Setup

Displays the Traffic Channel A Parameter Setup dialog box.

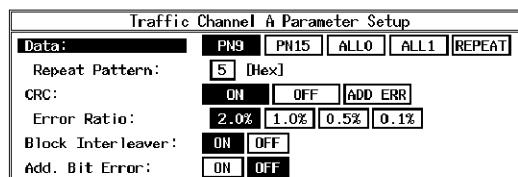

Figure 6-22 Traffic Channel A Parameter Setup Dialog Box

6.2 Reference

DATA	Selects the data pattern input to the realtime coder (Information data) or the data pattern input to the spreading section (Physical data).
PN9:	Selects a 9-stage PN code data pattern.
PN15:	Selects a 15-stage PN code data pattern.
ALL0:	Selects all zero data.
ALL1:	Selects all one data.
REP.:	Selects a data pattern consisting of the arbitrarily set four bits.
Rep. Pattern	Specifies a value [in hexadecimal] for the arbitrarily set four bits.
CRC	Selects a type of CRC to be added to the channel data.
ON:	Sets each CRC value correctly.
OFF:	Sets each CRC value to 0.
ADD ERR:	Adds an error to each CRC.
Error Ratio	Selects an error ratio that is added to CRC.
Block Interleaver	Toggles the Block Interleaving function on or off.
Add. Bit Error	Selects whether or not an error of 1% is added to the Information or Physical data pattern.

<When Reverse Is Set to RC3 or RC4>

FCH(TRCH B) Setup Displays the Traffic Channel B Parameter Setup dialog box.

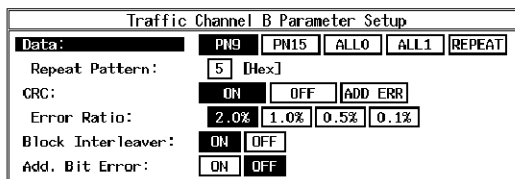

Figure 6-23 Traffic Channel B Parameter Setup Dialog Box

DATA	Selects the data pattern input to the realtime coder (Information data) or the data pattern input to the spreading section (Physical data).
PN9:	Selects a 9-stage PN code data pattern.
PN15:	Selects a 15-stage PN code data pattern.
ALL0:	Selects all zero data.
ALL1:	Selects all one data.
REP.:	Selects a data pattern consisting of the arbitrarily set four bits.

Rep. Pattern	Specifies a value [in hexadecimal] for the arbitrarily set four bits.
CRC	Selects a type of CRC to be added to the channel data. ON: Sets each CRC value correctly. OFF: Sets each CRC value to 0. ADD ERR: Adds an error to each CRC.
Error Ratio	Selects an error ratio that is added to CRC.
Block Interleaver	Toggles the Block Interleaving function on or off.
Add. Bit Error	Selects whether or not an error of 1% is added to the Information or Physical data pattern.

<When Reverse Is Set to RC3 or RC4>

SCH1(TRCH C) Setup Displays the Traffic Channel C Parameter Setup dialog box.

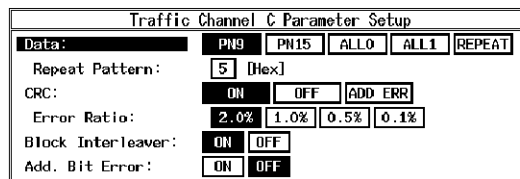

Figure 6-24 Traffic Channel C Parameter Setup Dialog Box

DATA	Selects the data pattern input to the realtime coder (Information data) or the data pattern input to the spreading section (Physical data). PN9: Selects a 9-stage PN code data pattern. PN15: Selects a 15-stage PN code data pattern. ALL0: Selects all zero data. ALL1: Selects all one data. REP.: Selects a data pattern consisting of the arbitrarily set four bits.
-------------	---

Rep. Pattern	Specifies a value [in hexadecimal] for the arbitrarily set four bits.
CRC	Selects a type of CRC to be added to the channel data. ON: Sets each CRC value correctly. OFF: Sets each CRC value to 0. ADD ERR: Adds an error to each CRC.
Error Ratio	Selects an error ratio that is added to CRC.
Block Interleaver	Toggles the Block Interleaving function on or off.

6.2 Reference

Add. Bit Error Selects whether or not an error of 1% is added to the Information or Physical data pattern.

<When Forward Is Set to RC1 or RC2>

FCH(TRCH A) Setup Displays the Traffic Channel A Parameter Setup dialog box.

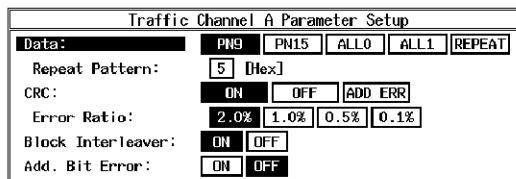

Figure 6-25 Traffic Channel A Parameter Setup Dialog Box

DATA Selects the data pattern input to the realtime coder (Information data) or the data pattern input to the spreading section (Physical data).

- PN9: Selects a 9-stage PN code data pattern.
- PN15: Selects a 15-stage PN code data pattern.
- ALL0: Selects all zero data.
- ALL1: Selects all one data.
- REP.: Selects a data pattern consisting of the arbitrarily set four bits.

Rep. Pattern Specifies a value [in hexadecimal] for the arbitrarily set four bits.

CRC Selects a type of CRC to be added to the channel data.

- ON: Sets each CRC value correctly.
- OFF: Sets each CRC value to 0.
- ADD ERR: Adds an error to each CRC.

Error Ratio Selects an error ratio that is added to CRC.

Block Interleaver Toggles the Block Interleaving function on or off.

Add. Bit Error Selects whether or not an error of 1% is added to the Information or Physical data pattern.

<When Forward Is Set to RC1 or RC2>

FCH(TRCH B) Setup Displays the Traffic Channel B Parameter Setup dialog box.

Traffic Channel B Parameter Setup					
Data:	<input checked="" type="radio"/> PN9	<input type="radio"/> PN15	<input type="radio"/> ALL0	<input type="radio"/> ALL1	<input type="radio"/> REPEAT
Repeat Pattern:	<input type="text" value="5"/> [Hex]				
CRC:	<input checked="" type="radio"/> ON	<input type="radio"/> OFF	<input type="button" value="ADD ERR"/>		
Error Ratio:	<input checked="" type="radio"/> 2.0%	<input type="radio"/> 1.0%	<input type="radio"/> 0.5%	<input type="radio"/> 0.1%	
Block Interleaver:	<input checked="" type="radio"/> ON	<input type="radio"/> OFF			
Add. Bit Error:	<input checked="" type="radio"/> ON	<input type="radio"/> OFF			

Figure 6-26 Traffic Channel B Parameter Setup Dialog Box

DATA

Selects the data pattern input to the realtime coder (Information data) or the data pattern input to the spreading section (Physical data).

PN9: Selects a 9-stage PN code data pattern.

PN15: Selects a 15-stage PN code data pattern.

ALL0: Selects all zero data.

ALL1: Selects all one data.

REP.: Selects a data pattern consisting of the arbitrarily set four bits.

Rep. Pattern

Specifies a value [in hexadecimal] for the arbitrarily set four bits.

CRC

Selects a type of CRC to be added to the channel data.

ON: Sets each CRC value correctly.

OFF: Sets each CRC value to 0.

ADD ERR: Adds an error to each CRC.

Error Ratio

Selects an error ratio that is added to CRC.

Block Interleaver

Toggles the Block Interleaving function on or off.

Add. Bit Error

Selects whether or not an error of 1% is added to the Information or Physical data pattern.

<When Forward Is Set to RC1 or RC2>

FCH(TRCH C) Setup

Displays the Traffic Channel C Parameter Setup dialog box.

Traffic Channel C Parameter Setup					
Data:	<input checked="" type="radio"/> PN9	<input type="radio"/> PN15	<input type="radio"/> ALL0	<input type="radio"/> ALL1	<input type="radio"/> REPEAT
Repeat Pattern:	<input type="text" value="5"/> [Hex]				
CRC:	<input checked="" type="radio"/> ON	<input type="radio"/> OFF	<input type="button" value="ADD ERR"/>		
Error Ratio:	<input checked="" type="radio"/> 2.0%	<input type="radio"/> 1.0%	<input type="radio"/> 0.5%	<input type="radio"/> 0.1%	
Block Interleaver:	<input checked="" type="radio"/> ON	<input type="radio"/> OFF			
Add. Bit Error:	<input checked="" type="radio"/> ON	<input type="radio"/> OFF			

Figure 6-27 Traffic Channel C Parameter Setup Dialog Box

6.2 Reference

DATA	Selects the data pattern input to the realtime coder (Information data) or the data pattern input to the spreading section (Physical data).
PN9:	Selects a 9-stage PN code data pattern.
PN15:	Selects a 15-stage PN code data pattern.
ALL0:	Selects all zero data.
ALL1:	Selects all one data.
REP.:	Selects a data pattern consisting of the arbitrarily set four bits.
Rep. Pattern	Specifies a value [in hexadecimal] for the arbitrarily set four bits.
CRC	Selects a type of CRC to be added to the channel data.
ON:	Sets each CRC value correctly.
OFF:	Sets each CRC value to 0.
ADD ERR:	Adds an error to each CRC.
Error Ratio	Selects an error ratio that is added to CRC.
Block Interleaver	Toggles the Block Interleaving function on or off.
Add. Bit Error	Selects whether or not an error of 1% is added to the Information or Physical data pattern.

<When Forward Is Set to RC3, RC4 or RC5>

SCH(TRCH A) Setup Displays the Traffic Channel A Parameter Setup dialog box.

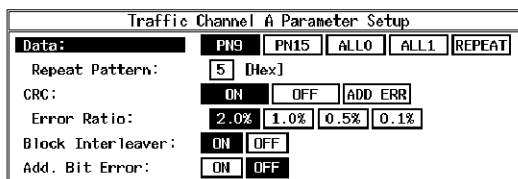

Figure 6-28 Traffic Channel A Parameter Setup Dialog Box

DATA	Selects the data pattern input to the realtime coder (Information data) or the data pattern input to the spreading section (Physical data).
PN9:	Selects a 9-stage PN code data pattern.
PN15:	Selects a 15-stage PN code data pattern.
ALL0:	Selects all zero data.
ALL1:	Selects all one data.
REP.:	Selects a data pattern consisting of the arbitrarily set four bits.

Rep. Pattern	Specifies a value [in hexadecimal] for the arbitrarily set four bits.
CRC	Selects a type of CRC to be added to the channel data. ON: Sets each CRC value correctly. OFF: Sets each CRC value to 0. ADD ERR: Adds an error to each CRC.
Error Ratio	Selects an error ratio that is added to CRC.
Block Interleaver	Toggles the Block Interleaving function on or off.
Add. Bit Error	Selects whether or not an error of 1% is added to the Information or Physical data pattern.

<When Forward Is Set to RC3, RC4 or RC5>

FCH(TRCH B) Setup Displays the Traffic Channel B Parameter Setup dialog box.

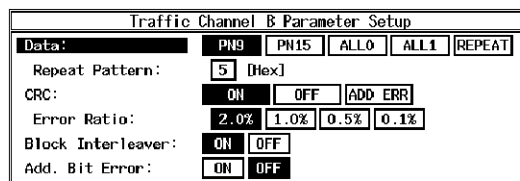

Figure 6-29 Traffic Channel B Parameter Setup Dialog Box

DATA	Selects the data pattern input to the realtime coder (Information data) or the data pattern input to the spreading section (Physical data). PN9: Selects a 9-stage PN code data pattern. PN15: Selects a 15-stage PN code data pattern. ALL0: Selects all zero data. ALL1: Selects all one data. REP.: Selects a data pattern consisting of the arbitrarily set four bits.
-------------	---

Rep. Pattern	Specifies a value [in hexadecimal] for the arbitrarily set four bits.
CRC	Selects a type of CRC to be added to the channel data. ON: Sets each CRC value correctly. OFF: Sets each CRC value to 0. ADD ERR: Adds an error to each CRC.
Error Ratio	Selects an error ratio that is added to CRC.
Block Interleaver	Toggles the Block Interleaving function on or off.

6.2 Reference

Add. Bit Error Selects whether or not an error of 1% is added to the Information or Physical data pattern.

<When Forward Is Set to RC3, RC4 or RC5>

SCH(TRCH C) Setup Displays the Traffic Channel C Parameter Setup dialog box.

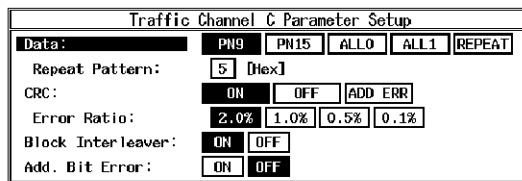

Figure 6-30 Traffic Channel C Parameter Setup Dialog Box

DATA Selects the data pattern input to the realtime coder (Information data) or the data pattern input to the spreading section (Physical data).

- PN9: Selects a 9-stage PN code data pattern.
- PN15: Selects a 15-stage PN code data pattern.
- ALL0: Selects all zero data.
- ALL1: Selects all one data.
- REP.: Selects a data pattern consisting of the arbitrarily set four bits.

Rep. Pattern Specifies a value [in hexadecimal] for the arbitrarily set four bits.

CRC Selects a type of CRC to be added to the channel data.

- ON: Sets each CRC value correctly.
- OFF: Sets each CRC value to 0.
- ADD ERR: Adds an error to each CRC.

Error Ratio Selects an error ratio that is added to CRC.

Block Interleaver Toggles the Block Interleaving function on or off.

Add. Bit Error Selects whether or not an error of 1% is added to the Information or Physical data pattern.

more 1/2 Displays Mod. (1/2) Menu.

Frequency & Level Displays the Frequency & Level menu.

Frequency Setup Displays the Frequency Parameter Setup dialog box.

Frequency Parameter Setup	
Freq Input:	<input type="radio"/> FREQUENCY <input type="radio"/> CHANNEL No
CH Start Freq.:	<input type="text" value="800.0000 MHz"/>
CH Step Freq.:	<input type="text" value="0.0300 MHz"/>
CH Start No.:	<input type="text" value="1"/>
Step Size:	<input type="text"/>

Figure 6-31 Frequency Parameter Setup Dialog Box

- Freq Input*** Selects the frequency entry mode.
FREQUENCY: Directly enters a frequency value.
CHANNEL No: Enters a channel number.
- CH Start Freq.*** Sets the channel start frequency.
- CH Step Freq.*** Sets the channel spacing.
- CH Start No.*** Sets the channel start number.
- Step Size*** Sets the step value of the step keys and data knob.
- Level Setup*** Displays the Level Parameter Setup dialog box.

Level Parameter Setup	
Unit:	<input checked="" type="radio"/> dBm <input type="radio"/> dBμVemf
Upper Limit:	<input type="text" value="0.0 dBm"/>
Level Offset:	<input type="radio"/> ON <input checked="" type="radio"/> OFF
Offset Value:	<input type="text"/>
Step Size:	<input type="text" value="5.0 dB"/>
ALC Mode:	<input type="radio"/> AUTO <input checked="" type="radio"/> S/H <input type="radio"/> HOLD

Figure 6-32 Level Parameter Setup Dialog Box

- Unit*** Selects the unit to display or enter the data.
dBm: Sets a level-related unit to dBm.
dBμVemf: Sets a level-related unit to dBμVemf.
- Upper Limit*** Sets the upper limit.
- Level Offset*** Toggles the level offset function on or off.
ON: Turns the level offset function on.
OFF: Turns the level offset function off.
- Offset Value*** Sets the level offset value.
- Step Size*** Sets the step value of the step keys.

6.2 Reference

ALC Mode

Selects the ALC operating mode.
Automatically selects the optimum operating mode depending on the R3562 settings. (For details, refer to the R3562 Operation manual.)

AUTO: Normal ALC

S/H: Sample and hold using the reference modulation pattern.

HOLD: ALC voltage hold when the reference modulation pattern is used.

NOTE: *When not set to the optimum operation mode, the output from the RF OUT terminal may deviate from the target value.*

Other

Displays the Other menu.

Clock & Timing Setup

Displays the Clock/Timing Signal Parameter Setup dialog box.

Clock/Timing Signal Parameter Setup					
Synth Ref In: [MHz]	1	1.2288	2	2.4576	4.9152
	5	9.8304	10	15	19.6608
	INTERNAL				
10MHz Ref Adj.:	0				
MOD-TB In: [MHz]	1	1.2288	2	2.4576	4.9152
	5	9.8304	10	15	19.6608
	INTERNAL				
Clock Out 1:	OFF	20nSec	25.6mSec	80nSec	
	2Sec	5mSec	CHIP CLOCK	EXT EVEN	
Clock Out 2:	OFF	20nSec	25.6mSec	80nSec	
	2Sec	5mSec	CHIP CLOCK	EXT EVEN	

Figure 6-33 Clock/Timing Signal Parameter Setup Dialog Box

Synthe Ref In

Selects the reference signal from the synthesizer.

- 1 MHz: Uses an external signal of 1 MHz.
- 1.2288 MHz: Uses an external signal of 1.2288 MHz.
- 2 MHz: Uses an external signal of 2 MHz.
- 2.4576 MHz: Uses an external signal of 2.4576 MHz.
- 4.9152 MHz: Uses an external signal of 4.9152 MHz.
- 5 MHz: Uses an external signal of 5 MHz.
- 9.8304 MHz: Uses an external signal of 9.8304 MHz.
- 10 MHz: Uses an external signal of 10 MHz.
- 15 MHz: Uses an external signal of 15 MHz.
- 19.6608 MHz: Uses an external signal of 19.6608 MHz.

INTERNAL: Uses the internal reference signal.

10MHz Ref Adj. Sets internal reference signal's frequency difference to be corrected.

MOD-TB In Selects the reference signal used for the modulation.

1 MHz: Uses an external signal of 1 MHz.

1.2288 MHz: Uses an external signal of 1.2288 MHz.

2 MHz: Uses an external signal of 2 MHz.

2.4576 MHz: Uses an external signal of 2.4576 MHz.

4.9152 MHz: Uses an external signal of 4.9152 MHz.

5 MHz: Uses an external signal of 5 MHz.

9.8304 MHz: Uses an external signal of 9.8304 MHz.

10 MHz: Uses an external signal of 10 MHz.

15 MHz: Uses an external signal of 15 MHz.

19.6608 MHz:
Uses an external signal of 19.6608 MHz.

INTERNAL: Uses the internal reference signal.

Clock Out 1/Clock Out 2

Outputs the modulation timing signals to the CLOCK OUT1 and CLOCK OUT2 connectors.

OFF: Turns the output signal off.

20 msec: Outputs the signals for the Traffic Channel frame period.

26.6 msec: Outputs the signals for the Sync Channel frame period.

80 msec: Outputs the signals for the Sync Channel super frame period.

2 sec: Outputs the even-second signal in the base band block.

5 msec: Outputs the signals for both the FCH and DCCH Channel frame periods.

CHIP CLOCK:
Outputs a chip clock of 1.2288 MHz.

EXT EVEN: Outputs an even-second signal which is input to the EXT TRIG terminal.

Ext I/Q Setup

Displays the External I/Q Parameter Setup dialog box.

6.2 Reference

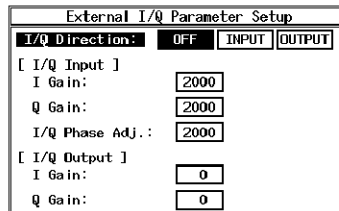

Figure 6-34 External I/Q Parameter Setup Dialog Box

I/Q Direction Exchanges the external IQ terminals between the input and output and selects the IQ signal paths to the IQ modulator.

OFF: Turns off the IQ output, and inputs the internal baseband signal to the IQ modulator.

INPUT: Inputs the IQ signal from the outside to the IQ modulator.

OUTPUT: Turns on the IQ output, and inputs the internal baseband signal to the IQ modulator.

NOTE: *The level and modulation accuracy of the RF output cannot be guaranteed while in the OUTPUT mode.*

[I/Q Input] Sets the parameter if I/Q Direction is set to Input.

I Gain Sets the gain of the amplifier that inputs the I signal.

Q Gain Sets the gain of the amplifier that inputs the Q signal.

I/Q Phase Adj.
Sets the phase difference to be corrected

[I/Q Output] Sets the parameter if I/Q Direction is set to Output.

I Gain Sets the gain of the amplifier that outputs the I signal.

Q Gain Sets the gain of the amplifier that outputs the Q signal.

Cal/Test Displays the Cal/Test menu.

AWCN The calibrations for the AWGN level and CDMA signal level are conducted and the correction can be used when the calibrations have been completed.

AWGN Cal Corr Toggles the AWGN calibration correction mode on or off.

ON: Allows the calibration correction to be performed using the acquired data.

OFF: Does not perform the calibration correction.

Modulator The IQ-modulator balance calibration is conducted. The correction data obtained from the calibration is ready to be used when the calibration has been completed.

Modulator Cal Corr

Toggles the modulator calibration correction mode on or off.

ON: Allows the calibration correction to be performed using the acquired data.

OFF: Does not perform the calibration correction.

Self Test

Performs the self test.

Save

Displays the Save Register List dialog box. Save is performed when the **ENTER** is pressed after the register has been selected.

Save Register List					
No.	I/Q Dir.	Link	Frequency	Level	Output
1:	OFF	FORWARD	800.000000MHz	33.0dBmVemf	ON
2:	INPUT	REVERSE	1000.000000MHz	33.0dBmVemf	ON
3:	empty				

Figure 6-35 Save Register List Dialog Box

Recall

Displays the Recall Register List dialog box. Recall is performed when the **ENTER** is pressed after the register has been selected.

Recall Register List					
No.	I/Q Dir.	Link	Frequency	Level	Output
1:	OFF	FORWARD	800.000000MHz	33.0dBmVemf	ON
2:	INPUT	REVERSE	1000.000000MHz	33.0dBmVemf	ON
3:	empty				

Figure 6-36 Recall Register List Dialog Box

Preset

Initializes the settings.

Modulation ON/OFF

Turns the RF output modulation function on or off.

ON: Modulates the RF output using transmission data.

OFF: Does not modulate the RF output.

Output ON/OFF

Turns the RF output on or off.

ON: Turns the RF signal on.

OFF: Turns the RF signal off.

Quit

Exits from the Rx Control option.

6.3 Setup Example

6.3 Setup Example

In this example, the output signals from the R3562, which are used for Reverse Link channel's FER measurements, are set.

Measurement conditions: The items to be measured are shown below. Set appropriate values for each measurement.

Output signal

- Frequency: 800 MHz
- Output level: -80 dBm
- Link: REVERSE
- Radio Configuration: RC1
- Rate: 9.6kbps

Setup

1. Connect the instrument as shown below.

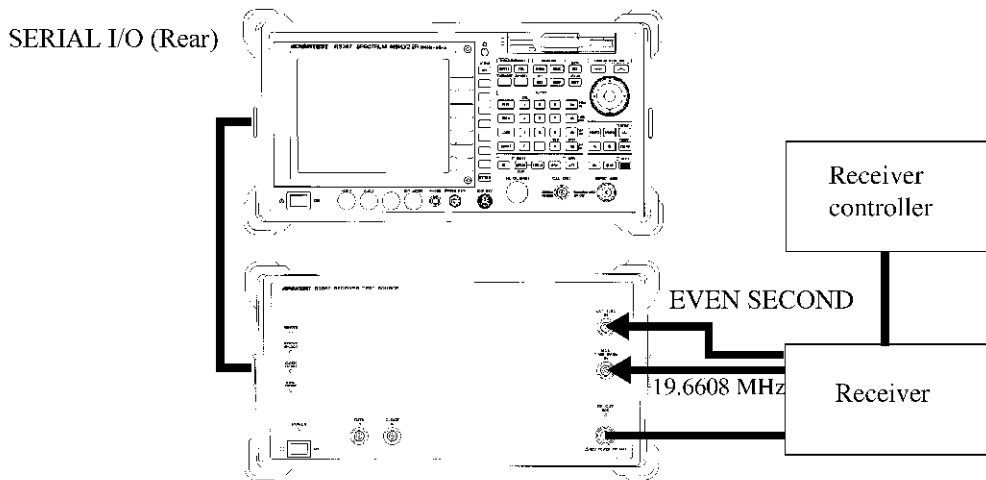

Figure 6-37 Connecting the DUT

Initialization

2. Press **ADVANCE**, *Rx Control*[R3562], *Other* and *Preset*.

Setting the output signal

3. Press **FREQ**, **8, 0, 0** and **MHz**.
4. Press **Level**, **-, 8, 0** and **GHz(dBm)**.

5. Press **Modulation** and **STD Setup**.
The STD Parameter Setup dialog box is displayed.

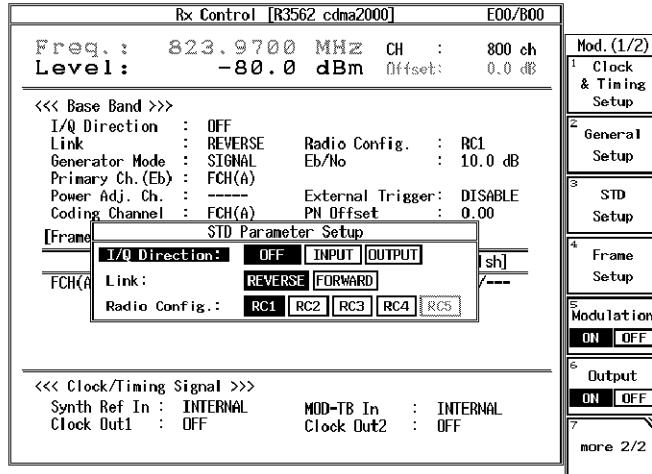

Figure 6-38 STD Parameter Setup Dialog Box

6. Set the following items.
I/Q direction:OFF
Link:REVERSE
Radio Config:RC1
7. Press **Clock & Timing Setup**.
The Clock/Timing Signal Parameter Setup dialog box is displayed.

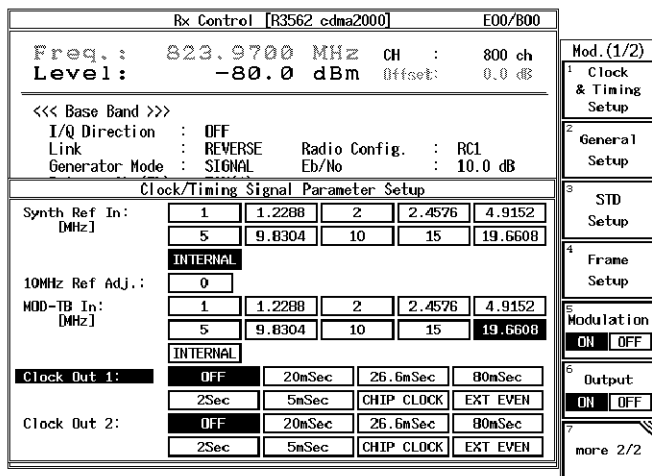

Figure 6-39 Clock/Timing Signal Parameter Setup Dialog Box

6.3 Setup Example

8. Set the following items.
 Synthe Ref In:INTERNAL
 MOD-TB In [MHz]:
 19.6608
9. Press **General Setup**.
 The General Parameter Setup dialog box is displayed.

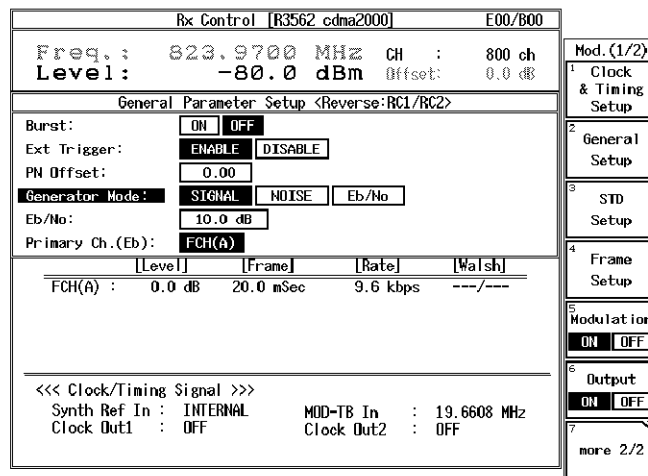

Figure 6-40 General Parameter Setup Dialog Box

10. Set the following items.
 Burst:OFF
 EXT Trigger:ENABLE
 PN Offset:0
 Generator Mode:SIGNAL
11. Press **Frame Setup**.
 The Frame Parameter Setup dialog box is displayed.

Rx Control [R3562 cdma2000] E00/B00	
Freq.:	823.9700 MHz CH : 800 ch
Level:	-80.0 dBm Offset: 0.0 dB
Frame Parameter Setup <Reverse:RC1>	
Coding Channel:	FCH(A) OFF
[FCH(A)]	Frame: 20mSec
	Rate [kbps]: 9.6 4.8 2.4 1.2
	FEC: CONVO
Coding Channel :	FCH(A) P11 Offset : 0.00
[Frame Setting]	
	[Level] [Frame] [Rate] [Walsh]
FCH(A) :	0.0 dB 20.0 mSec 9.6 kbps ---/---
<<< Clock/Timing Signal >>>	
Synth Ref In :	INTERNAL MOD-TB In : 19.6608 MHz
Clock Out1 :	OFF Clock Out2 : OFF

1 Clock & Timing Setup

2 General Setup

3 STD Setup

4 Frame Setup

5 Modulation ON OFF

6 Output ON OFF

7 more 2/2

Figure 6-41 Frame Parameter Setup Dialog Box <Reverse: RC1>

12. Set the following items.

Coding Channel:FCH(A)

[FCH(A)]:

Frame: 20msec

Rate [kbps]: 9.6

FEC: CONVO

6.3 Setup Example

13. Press *more 2/2* and *FCH(TRCH A)*
The Traffic Channel A Parameter Setup dialog box is displayed.

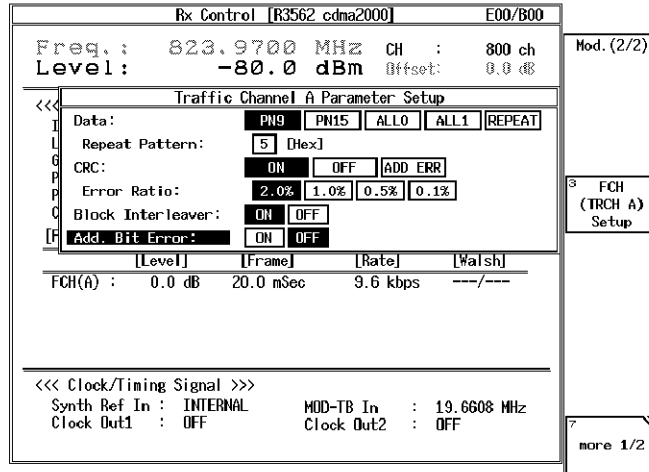

Figure 6-42 Traffic Channel A Parameter Setup Dialog Box

14. Set the following items.
Data:PN9
CRC:ON
Block Inter lever:ON
Add. Bit Error:OFF

- [S]**
- SACCH 3-3, 3-13
- Save 3-3, 3-16,
4-5, 4-16,
5-8, 5-25,
6-10, 6-45
- Save Register List 3-3, 4-5,
5-8, 6-10
- SCH(TRCH A) Setup 6-9, 6-38
- SCH(TRCH C) Setup 6-9, 6-40
- SCH1(TRCH C) Setup 6-9
- SCH2(TRCH A) Setup 6-9, 6-33
- Scramble 3-3, 3-13
- Scramble Code 3-3, 3-14
- Scrambling Code 5-6, 5-11,
5-13
- Self Test 4-5, 4-15,
5-8, 5-25,
6-10, 6-45
- Sens 3-3, 3-7
- Serial port setting 2-4
- Setup Example 6-46
- SINGLE 5-9, 6-11
- Slot 3-3
- Slot Config 3-3, 3-10
- Slot Setup 3-3, 3-12
- START 5-9, 6-11
- Start 3-3, 3-8
- STD Setup 5-6, 5-15,
6-6, 6-24
- Step 3-3, 3-8
- Step Size 4-5, 4-11,
4-12, 5-8,
5-22, 5-23,
6-10, 6-41
- STOP 5-9, 6-11
- Stop 3-3, 3-8
- Sync ON/OFF 3-3, 3-6,
3-9
- Sync Word 3-3, 3-15
- Synth Ref 4-5
- Synthe Ref In 5-6, 5-8,
5-10, 5-23,
6-6, 6-10,
6-12, 6-42
- [T]**
- Target BER 3-3, 3-8
- TFCI 5-7, 5-17,
5-19
- TPC Insert 5-7, 5-16,
5-19
- TPC Repeat Count 5-7, 5-17,
5-19
- Traffic PRBS 4-4, 4-9
- Trig Polarity 3-3, 3-10,
5-7, 5-21
- Trigger Delay 3-3, 3-11,
5-7, 5-21
- [U]**
- Unit 4-5, 4-12,
5-8, 5-22,
6-10, 6-41
- Upper Limit 4-5, 4-12,
5-8, 5-22,
6-10, 6-41
- User Scramble 3-3, 3-14
- User Scramble Code 3-3, 3-14
- [W]**
- Walsh Len 6-26, 6-28,
6-30
- Walsh No. 6-26, 6-28,
6-30

IMPORTANT INFORMATION FOR ADVANTEST SOFTWARE

PLEASE READ CAREFULLY: This is an important notice for the software defined herein. Computer programs including any additions, modifications and updates thereof, operation manuals, and related materials provided by Advantest (hereafter referred to as "SOFTWARE"), included in or used with hardware produced by Advantest (hereafter referred to as "PRODUCTS").

SOFTWARE License

All rights in and to the SOFTWARE (including, but not limited to, copyright) shall be and remain vested in Advantest. Advantest hereby grants you a license to use the SOFTWARE only on or with Advantest PRODUCTS.

Restrictions

- (1) You may not use the SOFTWARE for any purpose other than for the use of the PRODUCTS.
- (2) You may not copy, modify, or change, all or any part of, the SOFTWARE without permission from Advantest.
- (3) You may not reverse engineer, de-compile, or disassemble, all or any part of, the SOFTWARE.

Liability

Advantest shall have no liability (1) for any PRODUCT failures, which may arise out of any misuse (misuse is deemed to be use of the SOFTWARE for purposes other than its intended use) of the SOFTWARE. (2) For any dispute between you and any third party for any reason whatsoever including, but not limited to, infringement of intellectual property rights.

LIMITED WARRANTY

1. Unless otherwise specifically agreed by Seller and Purchaser in writing, Advantest will warrant to the Purchaser that during the Warranty Period this Product (other than consumables included in the Product) will be free from defects in material and workmanship and shall conform to the specifications set forth in this Operation Manual.
2. The warranty period for the Product (the "Warranty Period") will be a period of one year commencing on the delivery date of the Product.
3. If the Product is found to be defective during the Warranty Period, Advantest will, at its option and in its sole and absolute discretion, either (a) repair the defective Product or part or component thereof or (b) replace the defective Product or part or component thereof, in either case at Advantest's sole cost and expense.
4. This limited warranty will not apply to defects or damage to the Product or any part or component thereof resulting from any of the following:
 - (a) any modifications, maintenance or repairs other than modifications, maintenance or repairs (i) performed by Advantest or (ii) specifically recommended or authorized by Advantest and performed in accordance with Advantest's instructions;
 - (b) any improper or inadequate handling, carriage or storage of the Product by the Purchaser or any third party (other than Advantest or its agents);
 - (c) use of the Product under operating conditions or environments different than those specified in the Operation Manual or recommended by Advantest, including, without limitation, (i) instances where the Product has been subjected to physical stress or electrical voltage exceeding the permissible range and (ii) instances where the corrosion of electrical circuits or other deterioration was accelerated by exposure to corrosive gases or dusty environments;
 - (d) use of the Product in connection with software, interfaces, products or parts other than software, interfaces, products or parts supplied or recommended by Advantest;
 - (e) incorporation in the Product of any parts or components (i) provided by Purchaser or (ii) provided by a third party at the request or direction of Purchaser or due to specifications or designs supplied by Purchaser (including, without limitation, any degradation in performance of such parts or components);
 - (f) Advantest's incorporation or use of any specifications or designs supplied by Purchaser;
 - (g) the occurrence of an event of force majeure, including, without limitation, fire, explosion, geological change, storm, flood, earthquake, tidal wave, lightning or act of war; or
 - (h) any negligent act or omission of the Purchaser or any third party other than Advantest.
5. **EXCEPT TO THE EXTENT EXPRESSLY PROVIDED HEREIN, ADVANTEST HEREBY EXPRESSLY DISCLAIMS, AND THE PURCHASER HEREBY WAIVES, ALL WARRANTIES, WHETHER EXPRESS OR IMPLIED, STATUTORY OR OTHERWISE, INCLUDING, WITHOUT LIMITATION, (A) ANY WARRANTY OF MERCHANTABILITY OR FITNESS FOR A PARTICULAR PURPOSE AND (B) ANY WARRANTY OR REPRESENTATION AS TO THE VALIDITY, SCOPE, EFFECTIVENESS OR USEFULNESS OF ANY TECHNOLOGY OR ANY INVENTION.**
6. **THE REMEDY SET FORTH HEREIN SHALL BE THE SOLE AND EXCLUSIVE REMEDY OF THE PURCHASER FOR BREACH OF WARRANTY WITH RESPECT TO THE PRODUCT.**
7. **ADVANTEST WILL NOT HAVE ANY LIABILITY TO THE PURCHASER FOR ANY INDIRECT, INCIDENTAL, SPECIAL, CONSEQUENTIAL OR PUNITIVE DAMAGES, INCLUDING, WITHOUT LIMITATION, LOSS OF ANTICIPATED PROFITS OR REVENUES, IN ANY AND ALL CIRCUMSTANCES, EVEN IF ADVANTEST HAS BEEN ADVISED OF THE POSSIBILITY OF SUCH DAMAGES AND WHETHER ARISING OUT OF BREACH OF CONTRACT, WARRANTY, TORT (INCLUDING, WITHOUT LIMITATION, NEGLIGENCE), STRICT LIABILITY, INDEMNITY, CONTRIBUTION OR OTHERWISE. TORT (INCLUDING, WITHOUT LIMITATION, NEGLIGENCE), STRICT LIABILITY, INDEMNITY, CONTRIBUTION OR OTHERWISE.**
8. **OTHER THAN THE REMEDY FOR THE BREACH OF WARRANTY SET FORTH HEREIN, ADVANTEST SHALL NOT BE LIABLE FOR, AND HEREBY DISCLAIMS TO THE FULLEST EXTENT PERMITTED BY LAW ANY LIABILITY FOR, DAMAGES FOR PRODUCT FAILURE OR DEFECT, WHETHER ARISING OUT OF BREACH OF CONTRACT, TORT (INCLUDING, WITHOUT LIMITATION, NEGLIGENCE), STRICT LIABILITY, INDEMNITY, CONTRIBUTION OR OTHERWISE.**

CUSTOMER SERVICE DESCRIPTION

In order to maintain safe and trouble-free operation of the Product and to prevent the incurrence of unnecessary costs and expenses, Advantest recommends a regular preventive maintenance program under its maintenance agreement.

Advantest's maintenance agreement provides the Purchaser on-site and off-site maintenance, parts, maintenance machinery, regular inspections, and telephone support and will last a maximum of ten years from the date the delivery of the Product. For specific details of the services provided under the maintenance agreement, please contact the nearest Advantest office listed at the end of this Operation Manual or Advantest's sales representatives.

Some of the components and parts of this Product have a limited operating life (such as, electrical and mechanical parts, fan motors, unit power supply, etc.). Accordingly, these components and parts will have to be replaced on a periodic basis. If the operating life of a component or part has expired and such component or part has not been replaced, there is a possibility that the Product will not perform properly. Additionally, if the operating life of a component or part has expired and continued use of such component or part damages the Product, the Product may not be repairable. Please contact the nearest Advantest office listed at the end of this Operation Manual or Advantest's sales representatives to determine the operating life of a specific component or part, as the operating life may vary depending on various factors such as operating condition and usage environment.

SALES & SUPPORT OFFICES

Advantest Korea Co., Ltd.

22BF, Kyobo KangNam Tower,
1303-22, Seocho-Dong, Seocho-Ku, Seoul #137-070, Korea
Phone: +82-2-532-7071
Fax: +82-2-532-7132

Advantest (Suzhou) Co., Ltd.

Shanghai Branch Office:
Bldg. 6D, NO.1188 Gumei Road, Shanghai, China 201102 P.R.C.
Phone: +86-21-6485-2725
Fax: +86-21-6485-2726

Shanghai Branch Office:
406/F, Ying Building, Quantum Plaza, No. 23 Zhi Chun Road,
Hai Dian District, Beijing,
China 100083
Phone: +86-10-8235-3377
Fax: +86-10-8235-6717

Advantest (Singapore) Pte. Ltd.

438A Alexandra Road, #08-03/06
Alexandra Technopark Singapore 119967
Phone: +65-6274-3100
Fax: +65-6274-4055

Advantest America, Inc.

3201 Scott Boulevard, Suite, Santa Clara, CA 95054, U.S.A
Phone: +1-408-988-7700
Fax: +1-408-987-0691

ROHDE & SCHWARZ Europe GmbH

Mühldorfstraße 15 D-81671 München, Germany
(P.O.B. 80 14 60 D-81614 München, Germany)
Phone: +49-89-4129-13711
Fax: +49-89-4129-13723

ADVANTEST®

<http://www.advantest.co.jp>