ADVANTEST®

ADVANTEST CORPORATION

**INSTRUCTION
MANUAL**

**TR14501A/B AND
TR4172/4173**

CONNECTION MANUALS

MANUAL NUMBER 14501/4172/4173 EA 601

Before reselling to other corporations or re-exporting to other countries, you are required to obtain permission from both the Japanese Government under its Export Control Act and the U. S. Government under its Export Control Law.

TR14501A/B AND TR4172/4173
CONNECTION MANUALS

TABLE OF CONTENTS

TABLE OF CONTENTS

1. CONNECTION	1 - 1
1.1 MODIFICATIONS OF TR4172/4173 FOR CONNECTION OF TR14501A/B	1 - 1
1.2 PARTS FOR MODIFICATION OF TR4172/4173	1 - 2
1.3 MODIFICATION PROCEDURE	1 - 3
2. ADJUSTMENT AND INSPECTION	2 - 1
2.1 INTRODUCTION OF TR14501A/B ADJUSTMENT	2 - 1
2.2 CHECK AND ADJUSTMENT BEFORE POWER ON	2 - 2
2.2.1 Check before Power on	2 - 2
2.2.2 Check and Adjustment after Power on	2 - 3
2.3 UNIT TEST OF TR14501A/B BY MEANS OF TEST LEDs	2 - 4
2.3.1 Function of Each LED	2 - 4
2.3.2 TR14501A/B Unit Check by Test LEDs	2 - 4
2.3.3 Initial Check	2 - 5
2.3.4 Key Code Check	2 - 7
2.4 LOGIC CIRCUIT FUNCTION CHECK BY USING GPIB	2 - 8
2.4.1 Necessary Devices (Included in Necessary Devices for Specification Inspection)	2 - 8
2.4.2 Tested Items	2 - 8
2.4.3 Operation	2 - 9
2.5 TR14501A/B SPECIFICATION INSPECTION	2 - 10
2.5.1 Characteristics to be Inspected	2 - 10
2.5.2 Necessary Devices	2 - 14
2.5.3 Operation	2 - 15

TR14501A/B AND TR4172/4173
CONNECTION MANUALS

1.1 MODIFICATIONS OF TR4172/4173
FOR CONNECTION OF TR14501A/B

1. CONNECTION

1.1 MODIFICATIONS OF TR4172/4173 FOR CONNECTION OF TR14501A/B

To connect the TR14501A/B and TR4172/4173, the TR4172/4173 must be modified as follows:

- (1) Add the "TO TR14501A/B" connector to the rear panel of the display section.
- (2) Install a ROM to the option board (BGC-010481) in the display section.
- (3) Install the option bus board (BGC-012004) to the option slot in the display section and connect it to the above "TO TR14501A/B" connector.
- (4) If old version ROMs are used on the board CPU (BGP-010191) and memory (BGP-010192) in the display section, replace all of them for version up.

The parts necessary for these replacements except for the ROMs for replacement in (4) above are described in the TR14501A/B component parts list and TR4172/4173 electrical parts list.

TR14501A/B AND TR4172/4173
CONNECTION MANUALS

1.2 PARTS FOR MODIFICATION OF TR4172/4173

1.2 PARTS FOR MODIFICATION OF TR4172/4173

Parts name	Code name	Q'ty
Internal connection cable	DCB-RS1742x02-1	1
Option bus board	BGC-012004	1
Option memory III board	BGC-010481	1
ROMs for above board	SIS-001325 (TR4172) SIS-001483 (TR4173)	1
"TO TR14501A/B" nameplate	MNS-28765A	1
M2-6 screws and nuts		2 each

NOTE: ROMs for version up of the TR4172/4173 unit are excluded.

TR14501A/B AND TR4172/4173
CONNECTION MANUALS

1.3 MODIFICATION PROCEDURE

1.3 MODIFICATION PROCEDURE

- ① Remove the rear panel from the display section of the TR4172/4173. Connect the internal connection cable after removing the blind plate as shown in [Figure 1-1]. Also adhere the nameplate (MNS-28765A) at the illustrated position.

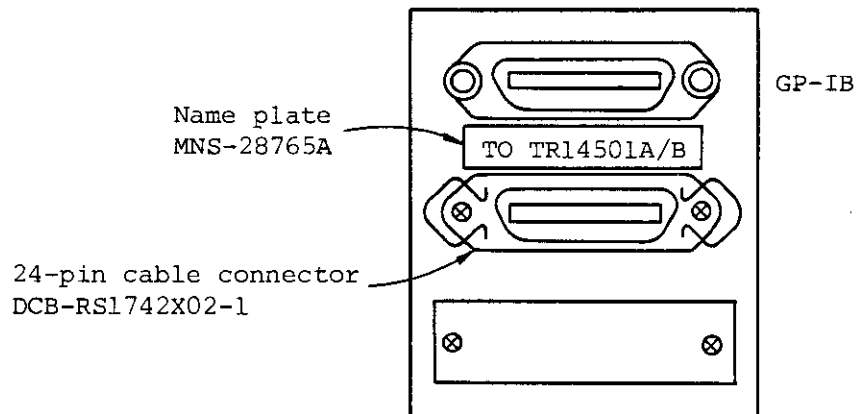

Figure 1-1 Rear Panel Modifications

- ② Install 64K ROM SIS-001325 (SIS-001483 for the TR4173) to the IC4 socket on option board BGC-010481. (If option 05 is already mounted, remove the ROMs from IC1 and IC4, and install SIS-001325 (SIS-001483 for the TR4173) to IC4.
- ③ Install two boards to option slots as shown in [Figure 1-2]. [Figure 1-2] is the bottom right portion of chapter 14 Display Section Top View -2 in TR4172 Instruction Manual. Connect the 26-pin connector of cable DCB-RS1742x02-1 installed in ① above to the 26-pin connector at the top of the option bus board (BGC-012004). (Carefully prevent the cable from being pinched when inserting these boards.)

TR14501A/B AND TR4172/4173
CONNECTION MANUALS

1.3 MODIFICATION PROCEDURE

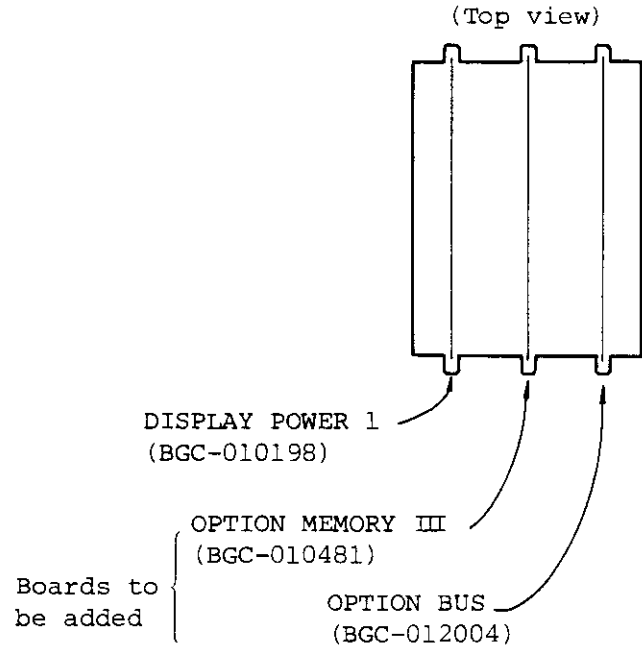

Figure 1-2 Board Addition to Option Slots

TR14501A/B AND TR4172/4173
CONNECTION MANUALS

2.1 INTRODUCTION OF TR14501A/B ADJUSTMENT

2. ADJUSTMENT AND INSPECTION

2.1 INTRODUCTION OF TR14501A/B ADJUSTMENT

The adjustment and inspection procedures for the TR14501A/B are as follows:

- (1) Appearance check
- ↓
- (2) Check and adjustment before power on
- ↓
- (3) Unit test by means of test LEDs
- ↓
- (4) Logic circuit function check by using GPIB
- ↓
- (5) Specification Inspection

Table 2-1 List of Materials for Inspection of TR14501A/B

Material	Name	Manufacturer	Q'ty
50Ω termination	26N50-SP (50 dB at 2 GHz)	WILTRON	1
75Ω termination	26N75	WILTRON	1
50Ω open-short	22N50	WILTRON	1
75Ω open-short	22N75	WILTRON	1
50Ω coaxial cable	DGM010-00300EE	Junkosha	1
75Ω coaxial cable	10N75-1	WILTRON	1
Through connector	2590	MIDWEST	1
Cable	57FE-324-201W (DCB-RR1779x01-1)	Advantest	1
Coaxial cable	MI-04 (DCB-FF0388-1)	Advantest	2

TR14501A/B AND TR4172/4173
CONNECTION MANUALS

2.2 CHECK AND ADJUSTMENT BEFORE POWER ON

2.2 CHECK AND ADJUSTMENT BEFORE POWER ON

2.2.1 Check before Power on

- (1) N-SMA connectors (4 places, J5 to J8) shall not easily be loosened with a hand

J5, J6, J7, J8

- (2) SMA connectors (12 places, CB1 to CB6) for semi-rigid cables shall not easily be loosened with a hand.

CB1, CB2, CB3, CB4, CB5, CB6

- (3) Terminations (R3 and R4) for terminals T1 and T2 of relay K2 (RFM-1C-24) shall not easily be loosened with a hand.

R3, R4

- (4) Is board BLR-012002 connector (J1 to J6) connected firmly? Is it locked in position (in case of a lock type)?

J1 to J6

- (5) Connect the cable (57FE-324-2P45W) actually to the control connector on the rear panel. Is it connected smoothly and locked in position?

CHECK

- (6) Is the tap change card in the fuse box (J1) on the rear panel set to the proper voltage value?

CHECK

- (7) Install ROM1 to ROM3 (IC23, 25 and 32: 64K) to the correct sockets.

ROM1 ← SIS-001326

ROM2 ← SIS-001327

ROM3 ← SIS-001328

NOTE: For ROM4 (IC37) and SIM-9511 (IC18), both sockets and ICs shall not be mounted.

- (8) Measure the resistance of the AC line to check the resistance values when the POWER switch is turned on and off.

Upon power on : Less than 100Ω

Upon power off: Infinite

TR14501A/B AND TR4172/4173
CONNECTION MANUALS

2.2 CHECK AND ADJUSTMENT BEFORE POWER ON

2.2.2 Check and Adjustment after Power on

- (1) Turn the POWER switch off and connect the AC line. Then turn the POWER switch on. Do all nine STATUS and BUSY test LEDs (on board BLR-012002) come on to start the initial check within 1 second?

CHECK

- (2) Are proper voltages output at two test points TP + 5 V and TP + 12 V?

TP + 5 V : 4.75 V to 5.25 V Actual value: _____ V
 TP + 12 V: 11.4 V to 12.6 V Actual value: _____ V

- (3) Adjust R47 so that the voltage at TP + 24 V becomes 24.0 V.

Adjustment TP + 24 V

- (4) Check jumper JP1 on board BLR-012002.

TR14501A → Without jumper

TR14501B → Jumpering with a plated wire

CHECK

TR14501A/B AND TR4172/4173
CONNECTION MANUALS

2.3 UNIT TEST OF TR14501A/B BY MEANS OF TEST LEDs

2.3 UNIT TEST OF TR14501A/B BY MEANS OF TEST LEDs

Unit functions of the TR14501A/B (hereafter called this unit) can be tested by means of ten LEDs (D1, D2, D4 to D11) on the controller board in this unit.

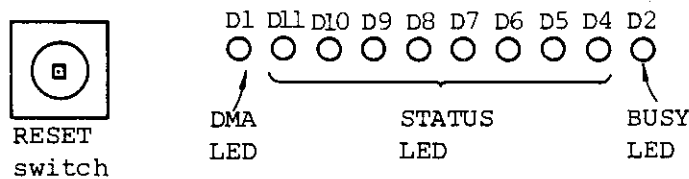

Figure 2-1 Test LED Arrangement on BLR-012002 Board

2.3.1 Function of Each LED

The function of each LED is explained below.

(1) DMA LED (D1)

Lit when this unit is in the process of DMA transfer according to the signal from the TR4172/4173.

The BUSAK signal at pin 23 of the CPU (μ PD780C-1, IC19) in this unit causes this LED to come on.

(2) BUSY LED (D2)

Lit when the CPU in this unit is executing a command. This LED is off when the CPU is in waiting state.

Comes on when the INT signal (pin 16) of the CPU (IC19) is set, and goes off by the software function at the end of command execution.

(3) STATUS LEDs (D4 to D11)

These LEDs display the error number during the initial check after the unit power on or after RESET switch operation. They display the key code when any of the front panel keys is pressed.

The display is made in eight binary bits: on for 1 and off for 0 in each bit.

2.3.2 TR14501A/B Unit Check by Test LEDs

The initial check of this unit starts when the POWER switch is turned on when the RESET switch is pressed on this unit. The following items are checked:

- Open-circuit or defect of (five) front panel LEDs
- ROM (three pieces) read error (by check sum method)
- RAM (four pieces) write/read error (check by writing 00_H and FF_H)

2.3 UNIT TEST OF TR14501A/B BY MEANS OF TEST LEDs

- Open-circuit or defect of (nine) front panel switches

At least the CPU and ROM1 must operate normally to carry out the initial check. Details are explained below.

2.3.3 Initial Check

The initial check is tested below sequence.
(The time required for the initial check is about 2 seconds.)

- (1) LED check
All LEDs on the front panel come on. At the same time, the STATUS and BUSY test LEDs come on for 0.6 second. (See Figure 2-2 (a).)
- (2) ROM check
The ROM check follows. The test LEDs sequentially display the checked ROM numbers. (See Figure 2-2 (b) to (d).) Upon detection of an error, the check is suspended and the number of the ROM causing the error is displayed with flashing at 0.6 second intervals according to [Figure 2-2].
- (3) RAM check
Then, RAM check starts. The test LEDs sequentially display the checked RAM numbers as shown in [Figure 2-2]. (See Figure 2-2 (e) to (h).) Upon detection of an error, the check is suspended and the number of the RAM causing the error is displayed with flashing at 0.6 second intervals according to [Figure 2-2].
- (4) End of initial check
If no error is detected in the RAM check, the BUSY LED kept on during the check goes off. At the same time all front panel switch LEDs go off except for the FORWARDS and TRANSMISSION. (See Figure 2-2 (i).) The time required for the initial check is about 2 seconds.

TR14501A/B AND TR4172/4173
CONNECTION MANUALS

2.3 UNIT TEST OF TR14501A/B BY MEANS OF TEST LEDs

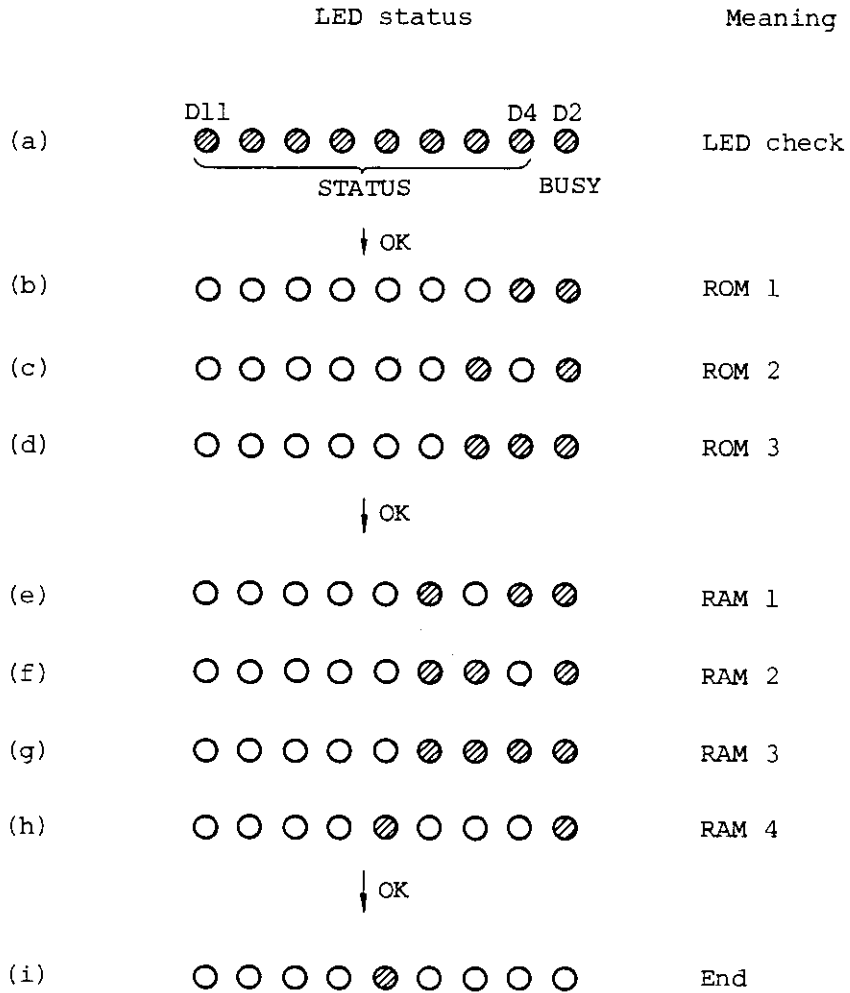

Figure 2-2 Test LEDs during Initial Check (About 2 seconds for steps (a) through (i))

TR14501A/B AND TR4172/4173
CONNECTION MANUALS

2.3 UNIT TEST OF TR14501A/B BY MEANS OF TEST LEDs

2.3.4 Key Code Check

After the end of the initial check, the test LEDs display the key code of the pressed key to make key function check possible. The correspondence between the key name and key code is shown below.

Key name	Test LEDs	Key code in hexadecimal notation
	D11 D4	
FORWARD		08H
	D11 D4	
REVERSE		09H
TRANSMISSION		0AH
REFLECTION		0BH
ALTERNATE		80H
IMPD		90H
STORE		A0H
CAL		B0H
MENU		C0H

Figure 2-3 Correspondence between Key Name and Key Code

TR14501A/B AND TR4172/4173
CONNECTION MANUALS

2.4 LOGIC CIRCUIT FUNCTION CHECK BY USING GPIB

2.4 LOGIC CIRCUIT FUNCTION CHECK BY USING GPIB

This aims to check the logic circuit operation by using the HP Series 200 computer (model 16, 26 or 36) to control the TR14501A/B and TR4172/4173.

2.4.1 Necessary Devices (Included in Necessary Devices for Specification Inspection)

- Hewlett-Packard Series 200 computer (model 16, 26 or 36)
- TR4172/4173 (connected at GPIB address 701 to TR14501A/B)
- TR14501A/B

Connect the above devices as illustrated below (or connect in the same way as for specification inspection).

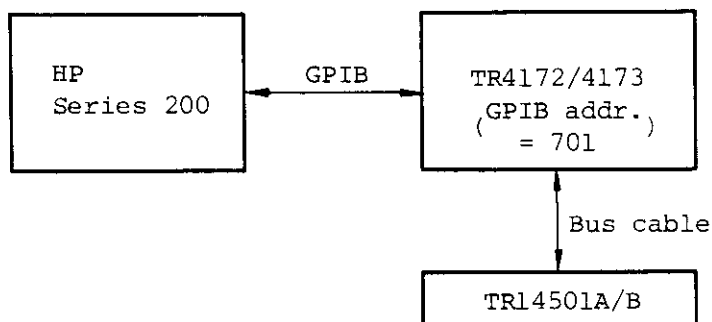

Figure 2-4 Connection for Check

2.4.2 Tested Items

(1) Type check

TR4172/4173 addresses 7820_H to 7827_H are used for connection with the TR14501A/B. Reading 7823_H causes F6_H or F7_H from the TR14501A/B board (BLR-012002).

F6_H is read for the TR14501A, and F7_H for the TR14501B.

This operation is checked, and an error results if the read data is other than F6_H or F7_H.

(2) Handshake check

When the TR4172/4173 is set to the master reset mode, a command is sent to the TR14501A/B.

After initialization, the TR14501A/B sends a command back to the TR4172/4173. The CRT of the TR4172/4173 momentarily displays "TR14501A" (or "TR14501B") and then "P: -> T".

An error results if the display does not appear.

TR14501A/B AND TR4172/4173
CONNECTION MANUALS

2.4 LOGIC CIRCUIT FUNCTION CHECK BY USING GPIB

(3) DMA check

This aims to check the DMA transfer between the TR4172/4173 and TR14501A/B. Trace B data in 2002 bytes of the TR4172/4173 is sent to the memory in the TR14501A/B and then sent back from the memory to the TR4172/4173 to check if they agree with each other. This test is repeated 100 times.

An error results if there is any disagreement.

(4) Impedance mode check

In the impedance measurement mode (Smith Chart Display), the CPU in the TR14501A/B operates as the sub-CPU for the TR4172/4173 for conversion of the marker normalizing impedance and equivalent LC. This function is checked. The normalizing impedance and equivalent LC are displayed at 20 points on the Smith Chart and compared with the calculation results by the desktop computer. An error results, if there is any disagreement.

2.4.3 Operation

- ① Connect the devices as shown in [Figure 2-4], and start the computer with BASIC.

(The GPIB address of the TR4172/4173 shall be set to 701.)

- ② Set the floppy disk containing the test program to the computer, and key in

LOAD "14501LOGIC"

to load the test program.

- ③ Pressing the key after loading causes the computer CRT to display the following message:

TYPE? (A: TR14501A, B: TR14501B)

Key in A if the tested device is the TR14501A, or B if the tested device is the TR14501B.

- ④ Now, the check starts. If an error exists, the test is suspended there and the corresponding error message is displayed on the CRT. (The required time is about 30 seconds.)

- ⑤ If the check ends without an error,

LOGIC OK

is displayed to indicate an acceptance by the test.

2.5 TR14501A/B SPECIFICATION INSPECTION

2.5.1 Characteristics to be Inspected

(1) Directivity

The directivity is the dynamic range during reflection measurement. The level difference between the test port open (full reflection) state and the termination (no reflection state) is measured. This is determined by the directivity of the bridge in use.

[Figure 2-5] shows the VSWR bridge signal flow.

A leakage signal D due to bridge unbalance, etc. occurs in addition to the reflection signal from the DUT, and this leakage signal determines the directivity

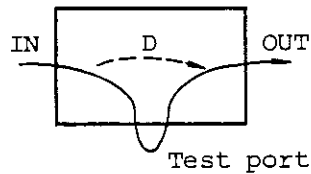

Figure 2-5 Directivity of VSWR Bridge

The termination resistor is connected for this measurement to establish the no reflection state. Since the termination resistor available at present has a return loss of 50 dB (see Table 2-1), an error in D results due to the influence of reflection T of the termination as shown in [Figure 2-6].

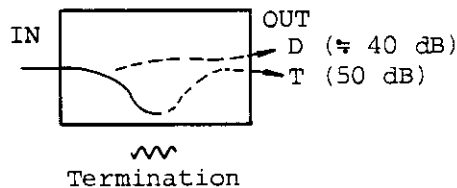

Figure 2-6 Influence of Termination during Directivity Measurement

TR14501A/B AND TR4172/4173
CONNECTION MANUALS

2.5 TR14501A/B SPECIFICATION INSPECTION

Since elimination of this error is difficult at present, WILTRON's special termination

26N50-SP (50 dB at 2 GHz)

is adapted. Considering the error due to this termination, 39.0 dB or more is used instead of the company specification of 42 dB or more for the TR14501A.

Therefore, the directivity is acceptable if the actually measured value (using the above termination) is 39 dB or more.

In the program, the level of worst directivity (peak point) in the band is output.

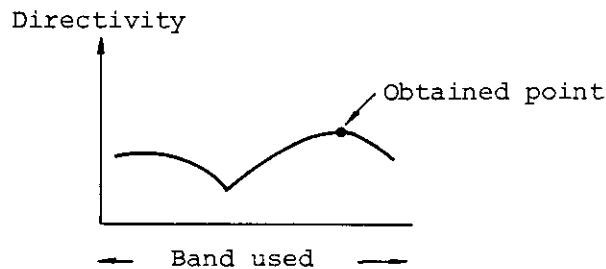

Figure 2-7

(2) Test port return loss

The test port return loss is the return loss on the terminated side port (port 2 in forward reflection for example) out of two test ports (port-1 and port-2) in reflection measurement.

For measurement, connect port-1 and port-2 with the specified cable and measure the return loss on the other side. (See Figure 2-8.)

For the TR14501A, the directivity is to be measured in two frequency bands. The worst value is obtained for each of these frequency bands (by using the next peak search function of the TR4172/4173).

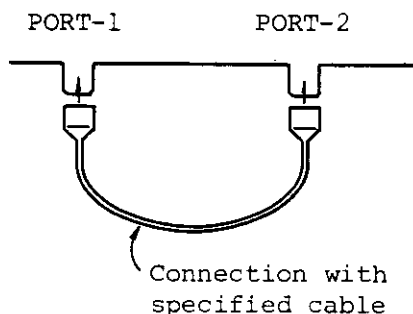

Figure 2-8 Connection for Test Port Return Loss Measurement

(3) Frequency response

The frequency response between the INPUT and OUTPUT terminals of the TR14501A/B with through connection between test ports for transmission characteristic measurement, or with open connection between test ports for reflection characteristic measurement.

In the calibration before measurement, therefore, normalize with TR4172/4173 including the cable by using the specified N-N through connector.

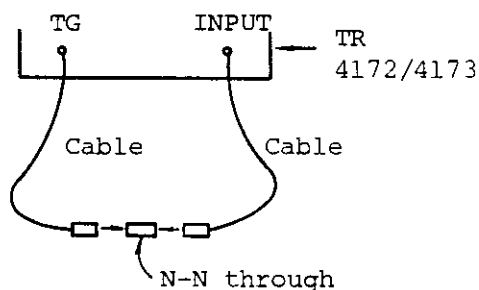

Figure 2-9 Calibration before Frequency Response Measurement

The program outputs the difference between the peak response and negative response. At the same time, the peak level is output as the insertion loss.

(4) Open/short ratio

Return loss level difference between open connection to test ports and short connection to test ports.

As shown in [Figure 2-10], test port reflection A is further reflected in the test set to cause an error component B. Since the phase of B is reverse between open and short, a level difference results as a result of addition and subtraction as shown in [Figure 2-11].

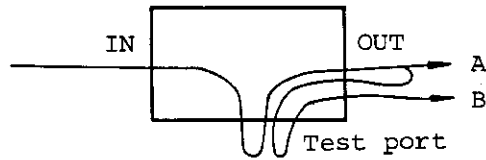

Figure 2-10 Open/Short Ratio

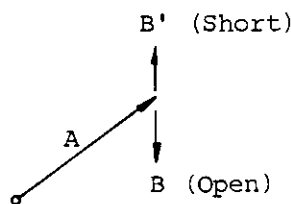

Figure 2-11 Reflected Wave Vectors at Open and Short Connection

The program adopts the maximum value (peak) of the absolute value of the return losses in open and short connections.

(5) Crosstalk between input and output

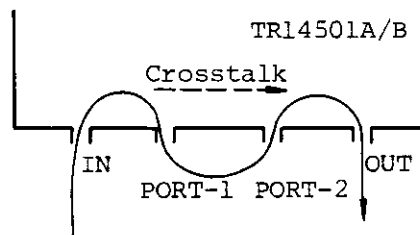

Figure 2-12 Crosstalk between Input and Output

The crosstalk between the input and output when port-1 and port-2 are open during transmission measurement. Since TG leak of the TR4172/4173 and crosstalk between connecting cables adversely affect this measurement, carry out TG tracking adjustment of the TR4172/4173 (instruction in the program) before the test and use the (specified) double shielded cables for connection to the TR4172/4173.

TR14501A/B AND TR4172/4173
CONNECTION MANUALS

2.5 TR14501A/B SPECIFICATION INSPECTION

2.5.2 Necessary Devices

- TR4172/4173 (modified for connection to the TR14501A/B)
- Hewlett-Packard Series 200 computer (model 16, 26 or 36): 1 system
- Materials in Table 2-3
- Inspection software (minifloppy or micro-floppy disk x 1)

Table 2-2 Necessary Materials for Measurement of Each Characteristic
in TR14501A/B Specification Inspection

Material Characteristic	Termination	Open-short	Through cable	Through connector
1. Directivity	o			
2. Test port return loss			o	
3. Transmission frequency response			o	o
4. Reflection frequency response				
5. Open/short ratio		o		
6. Crosstalk between input and output			o	

Table 2-3 List of Necessary Materials for TR14501A/B
Specification Inspection

	TR14501A	Q'ty	TR14501B	Q'ty
Termination	26N50-SP (50 dB at 2 GHz)	1	26N75	1
Open-short	22N50	1	22N75	1
Through cable	DGM010-00300EE	1	10N75-1	1
Through connector	2590			1
Bus cable (extension)	57FE-324-201W			1
RF connection cable (for N-N, TR4172 connection)	MI-04			2

2.5 TR14501A/B SPECIFICATION INSPECTION

2.5.3 Operation

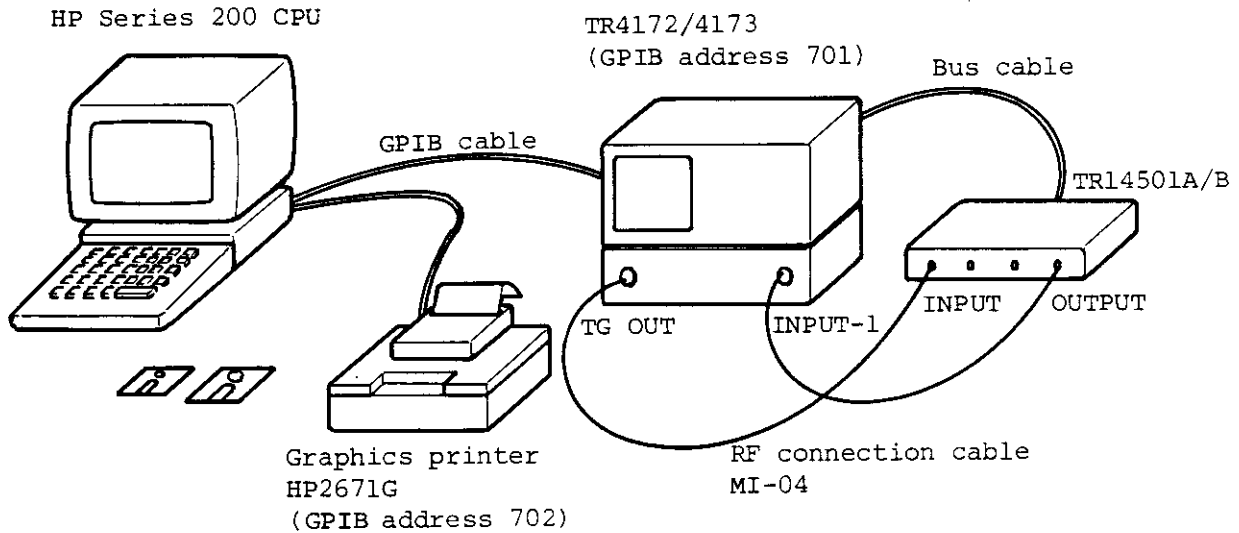

Figure 2-13 Connection for TR14501A/B Specification Inspection

- ① Connect the devices as shown in [Figure 2-13]. Initiate BASIC on the CPU.
- ② Set the inspection software to the CPU, and key in LOAD "TR14501A" (for inspection of TR14501A) or LOAD "TR14501B" (for inspection of TR14501B).
- ③ After program loading, press the key to start the inspection.
- ④ Press the key.
- ⑤ Key in the test date and time, and to serial No. of TR14501A/B.
- ⑥ Obtain the specification for each characteristic according to the message on the CRT screen of the CPU.
- ⑦ After the end of testing all characteristics, the CRT screen of the CPU displays TEST END! to complete the inspection.

Result

Data acquisition according to the above steps results in inspection result data output on the printer as one test data sheet. It corresponds to all characteristics of the company specification of the TR14501A/B.

TR14501A/B AND TR4172/4173
CONNECTION MANUALS

LIST OF FIGURES

LIST OF FIGURES

<u>Figure No.</u>	<u>Title</u>	<u>Page</u>
Figure 1-1	Rear Panel Modifications	1 - 3
Figure 1-2	Board Addition to Option Slots	1 - 4
Figure 2-1	Test LED Arrangement on BLR-012002 Board	2 - 4
Figure 2-2	Test LEDs during Initial Check (About 2 seconds for steps (a) through (i))	2 - 6
Figure 2-3	Correspondence between Key Name and Key Code	2 - 7
Figure 2-4	Connection for Check	2 - 8
Figure 2-5	Directivity of VSWR Bridge	2 - 10
Figure 2-6	Influence of Termination during Directivity Measurement	2 - 10
Figure 2-7		2 - 11
Figure 2-8	Connection for Test Port Return Loss Measurement	2 - 12
Figure 2-9	Calibration before Frequency Response Measurement	2 - 12
Figure 2-10	Open/Short Ratio	2 - 13
Figure 2-11	Reflected Wave Vectors at Open and Short Connection	2 - 13
Figure 2-12	Crosstalk between Input and Output	2 - 13
Figure 2-13	Connection for TR14501A/B Specification Inspection	2 - 15

TR14501A/B AND TR4172/4173
CONNECTION MANUALS

LIST OF TABLES

LIST OF TABLES

<u>Table No.</u>	<u>Title</u>	<u>Page</u>
Table 2-1	List of Materials for Inspection of TR14501A/B	2 - 1
Table 2-2	Necessary Materials for Measurement of Each Characteristic in TR14501A/B Specification Inspection	2 - 14
Table 2-3	List of Necessary Materials for TR14501A/B Specification Inspection	2 - 14

TR14501A/B AND TR4172/4173
CONNECTION MANUALS

LIST OF EXAMPLES

LIST OF EXAMPLES

<u>Example No.</u>	<u>Title</u>	<u>Page</u>
--------------------	--------------	-------------

(No example numbers are assigned in this manual.)

IMPORTANT INFORMATION FOR ADVANTEST SOFTWARE

PLEASE READ CAREFULLY: This is an important notice for the software defined herein. Computer programs including any additions, modifications and updates thereof, operation manuals, and related materials provided by Advantest (hereafter referred to as "SOFTWARE"), included in or used with hardware produced by Advantest (hereafter referred to as "PRODUCTS").

SOFTWARE License

All rights in and to the SOFTWARE (including, but not limited to, copyright) shall be and remain vested in Advantest. Advantest hereby grants you a license to use the SOFTWARE only on or with Advantest PRODUCTS.

Restrictions

- (1) You may not use the SOFTWARE for any purpose other than for the use of the PRODUCTS.
- (2) You may not copy, modify, or change, all or any part of, the SOFTWARE without permission from Advantest.
- (3) You may not reverse engineer, de-compile, or disassemble, all or any part of, the SOFTWARE.

Liability

Advantest shall have no liability (1) for any PRODUCT failures, which may arise out of any misuse (misuse is deemed to be use of the SOFTWARE for purposes other than its intended use) of the SOFTWARE. (2) For any dispute between you and any third party for any reason whatsoever including, but not limited to, infringement of intellectual property rights.

LIMITED WARRANTY

1. Unless otherwise specifically agreed by Seller and Purchaser in writing, Advantest will warrant to the Purchaser that during the Warranty Period this Product (other than consumables included in the Product) will be free from defects in material and workmanship and shall conform to the specifications set forth in this Operation Manual.
2. The warranty period for the Product (the "Warranty Period") will be a period of one year commencing on the delivery date of the Product.
3. If the Product is found to be defective during the Warranty Period, Advantest will, at its option and in its sole and absolute discretion, either (a) repair the defective Product or part or component thereof or (b) replace the defective Product or part or component thereof, in either case at Advantest's sole cost and expense.
4. This limited warranty will not apply to defects or damage to the Product or any part or component thereof resulting from any of the following:
 - (a) any modifications, maintenance or repairs other than modifications, maintenance or repairs (i) performed by Advantest or (ii) specifically recommended or authorized by Advantest and performed in accordance with Advantest's instructions;
 - (b) any improper or inadequate handling, carriage or storage of the Product by the Purchaser or any third party (other than Advantest or its agents);
 - (c) use of the Product under operating conditions or environments different than those specified in the Operation Manual or recommended by Advantest, including, without limitation, (i) instances where the Product has been subjected to physical stress or electrical voltage exceeding the permissible range and (ii) instances where the corrosion of electrical circuits or other deterioration was accelerated by exposure to corrosive gases or dusty environments;
 - (d) use of the Product in connection with software, interfaces, products or parts other than software, interfaces, products or parts supplied or recommended by Advantest;
 - (e) incorporation in the Product of any parts or components (i) provided by Purchaser or (ii) provided by a third party at the request or direction of Purchaser or due to specifications or designs supplied by Purchaser (including, without limitation, any degradation in performance of such parts or components);
 - (f) Advantest's incorporation or use of any specifications or designs supplied by Purchaser;
 - (g) the occurrence of an event of force majeure, including, without limitation, fire, explosion, geological change, storm, flood, earthquake, tidal wave, lightning or act of war; or
 - (h) any negligent act or omission of the Purchaser or any third party other than Advantest.
5. **EXCEPT TO THE EXTENT EXPRESSLY PROVIDED HEREIN, ADVANTEST HEREBY EXPRESSLY DISCLAIMS, AND THE PURCHASER HEREBY WAIVES, ALL WARRANTIES, WHETHER EXPRESS OR IMPLIED, STATUTORY OR OTHERWISE, INCLUDING, WITHOUT LIMITATION, (A) ANY WARRANTY OF MERCHANTABILITY OR FITNESS FOR A PARTICULAR PURPOSE AND (B) ANY WARRANTY OR REPRESENTATION AS TO THE VALIDITY, SCOPE, EFFECTIVENESS OR USEFULNESS OF ANY TECHNOLOGY OR ANY INVENTION.**
6. **THE REMEDY SET FORTH HEREIN SHALL BE THE SOLE AND EXCLUSIVE REMEDY OF THE PURCHASER FOR BREACH OF WARRANTY WITH RESPECT TO THE PRODUCT.**
7. **ADVANTEST WILL NOT HAVE ANY LIABILITY TO THE PURCHASER FOR ANY INDIRECT, INCIDENTAL, SPECIAL, CONSEQUENTIAL OR PUNITIVE DAMAGES, INCLUDING, WITHOUT LIMITATION, LOSS OF ANTICIPATED PROFITS OR REVENUES, IN ANY AND ALL CIRCUMSTANCES, EVEN IF ADVANTEST HAS BEEN ADVISED OF THE POSSIBILITY OF SUCH DAMAGES AND WHETHER ARISING OUT OF BREACH OF CONTRACT, WARRANTY, TORT (INCLUDING, WITHOUT LIMITATION, NEGLIGENCE), STRICT LIABILITY, INDEMNITY, CONTRIBUTION OR OTHERWISE. TORT (INCLUDING, WITHOUT LIMITATION, NEGLIGENCE), STRICT LIABILITY, INDEMNITY, CONTRIBUTION OR OTHERWISE.**
8. **OTHER THAN THE REMEDY FOR THE BREACH OF WARRANTY SET FORTH HEREIN, ADVANTEST SHALL NOT BE LIABLE FOR, AND HEREBY DISCLAIMS TO THE FULLEST EXTENT PERMITTED BY LAW ANY LIABILITY FOR, DAMAGES FOR PRODUCT FAILURE OR DEFECT, WHETHER ARISING OUT OF BREACH OF CONTRACT, TORT (INCLUDING, WITHOUT LIMITATION, NEGLIGENCE), STRICT LIABILITY, INDEMNITY, CONTRIBUTION OR OTHERWISE.**

CUSTOMER SERVICE DESCRIPTION

In order to maintain safe and trouble-free operation of the Product and to prevent the incurrence of unnecessary costs and expenses, Advantest recommends a regular preventive maintenance program under its maintenance agreement.

Advantest's maintenance agreement provides the Purchaser on-site and off-site maintenance, parts, maintenance machinery, regular inspections, and telephone support and will last a maximum of ten years from the date the delivery of the Product. For specific details of the services provided under the maintenance agreement, please contact the nearest Advantest office listed at the end of this Operation Manual or Advantest's sales representatives.

Some of the components and parts of this Product have a limited operating life (such as, electrical and mechanical parts, fan motors, unit power supply, etc.). Accordingly, these components and parts will have to be replaced on a periodic basis. If the operating life of a component or part has expired and such component or part has not been replaced, there is a possibility that the Product will not perform properly. Additionally, if the operating life of a component or part has expired and continued use of such component or part damages the Product, the Product may not be repairable. Please contact the nearest Advantest office listed at the end of this Operation Manual or Advantest's sales representatives to determine the operating life of a specific component or part, as the operating life may vary depending on various factors such as operating condition and usage environment.

SALES & SUPPORT OFFICES

Advantest Korea Co., Ltd.

22BF, Kyobo KangNam Tower,
1303-22, Seocho-Dong, Seocho-Ku, Seoul #137-070, Korea
Phone: +82-2-532-7071
Fax: +82-2-532-7132

Advantest (Suzhou) Co., Ltd.

Shanghai Branch Office:
Bldg. 6D, NO.1188 Gumei Road, Shanghai, China 201102 P.R.C.
Phone: +86-21-6485-2725
Fax: +86-21-6485-2726

Shanghai Branch Office:
406/F, Ying Building, Quantum Plaza, No. 23 Zhi Chun Road,
Hai Dian District, Beijing,
China 100083
Phone: +86-10-8235-3377
Fax: +86-10-8235-6717

Advantest (Singapore) Pte. Ltd.

438A Alexandra Road, #08-03/06
Alexandra Technopark Singapore 119967
Phone: +65-6274-3100
Fax: +65-6274-4055

Advantest America, Inc.

3201 Scott Boulevard, Suite, Santa Clara, CA 95054, U.S.A
Phone: +1-408-988-7700
Fax: +1-408-987-0691

ROHDE & SCHWARZ Europe GmbH

Mühldorfstraße 15 D-81671 München, Germany
(P.O.B. 80 14 60 D-81614 München, Germany)
Phone: +49-89-4129-13711
Fax: +49-89-4129-13723

ADVANTEST®

<http://www.advantest.co.jp>